

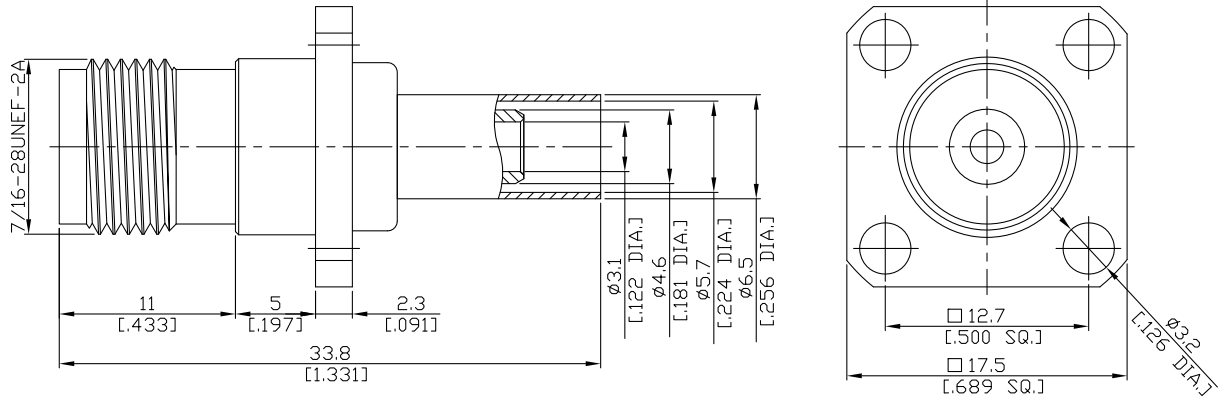

TNC Straight 4 Hole Panel Flange  
Cable Jack

TNC2CBF50-G142A/H3



All dimensions are in mm [inch]  
Tolerances according to DIN ISO 2768-mH

**Interface**

According to IEC 60169-17; MIL-C-39012; MIL-STD-348A/313

**Electrical Data**

Impedance 50 Ω  
Frequency DC to 11 GHz  
VSWR (Return Loss) ≤ 1.15 (≥ 23.1dB) ,DC to 2.5 GHz  
Insertion Loss ≤ 0.05 x √F (GHz) dB

- Limitations are possible due to the used cable type -

**Mechanical Data**

Coupling mechanisms Screw-lock  
Centre contact Soldered or Crimped  
Cable entry Crimped

**Environmental Data**

Temperature range -65°C to +165°C  
RoHS compliant

**Material And Plating**

Connector parts	Material	Plating
Centre contact	Phosphor Bronze	Gold plating(Nickel underplated)
Body	Brass	Nickel
Insulator	PTFE	
Crimp ferrules	Brass	Copper-Tin-Zinc Alloy

**Suitable Cables**

RG 55, RG 142, RG 223, RG 400

**Packing**

Single or 100

**Related Document**

Mounting Dimension MD9