

| REVISIONS | | | | | |
|-----------|-----|------------------------------|-----------|-----|------|
| REV | ECO | DESCRIPTION | DATE | BY | APPR |
| A1 | - | TECHNICAL DATA SHEET RELEASE | 12-MAY-14 | KMM | RFC |

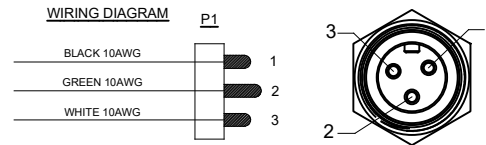
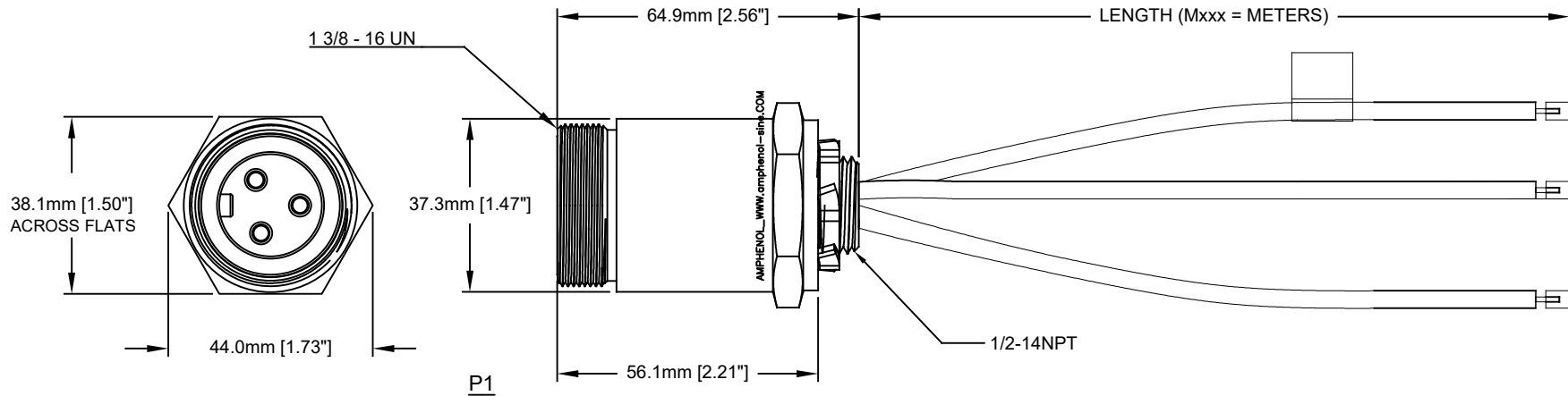

TECHNICAL DATA:

- MATERIALS:**
HOUSING: MACHINED ALUMINUM, ANODIZED
INSULATION INSERT: THERMOPLASTIC, UL 94/V-0
CONTACT: GOLD FLASH PLATING OVER COPPER ALLOY
CONDUCTOR INSULATION: PVC
NUMBER OF CONDUCTORS: (3) 10AWG
- ELECTRICAL DATA:**
CURRENT (MAX): 30A
VOLTAGE (MAX): 600V AC/DC
INSULATION RESISTANCE (MIN): 5000M OHMS
DIELECTRIC TEST VOLTAGE: 2200V
- MECHANICAL DATA:**
KNOCKOUT HOLE SIZE FOR PANEL MOUNT: 22.2mm [.88"]
TEMPERATURE RANGE: -40°C TO 90°C
PROTECTION: IP67 (MATED CONDITION)
MATING CYCLES: >500
VIBRATION RESISTANCE PER MIL-STD-202 METHOD 204
THERMAL SHOCK PER MIL-STD-202 METHOD 207
48 HOUR SALT SPRAY PER MIL-STD-202 METHOD 101
- RoHS COMPLIANT**
- UL 2237 LISTED ASSEMBLY**
UL FILE NUMBERS: E339703

| TOLERANCE | |
|----------------------------|-----------------------------|
| 0-2.99 M = +100.0/-25.0mm | 0-9.99 FT = +4" / -1" |
| 3-8.99 M = +150.0/-25.0mm | 10.00-29.99 FT = +6" / -1" |
| 9-14.99 M = +300.0/-25.0mm | 30.00-49.99 FT = +12" / -1" |
| 15-OVER M = +450.0/-25.0mm | 50 FT-OVER = +18" / -1" |

| QUANTITY | PART NUMBER | DESCRIPTION | ITEM |
|---------------------------------------|-------------|--|--------------|
| MATERIALS LIST | | | |
| UNLESS OTHERWISE SPECIFIED | | SIGNATURES | |
| 1) All dimensions are in metric (mm). | | DATE | |
| 2) Tolerances are as follows: | | DRAWN: KMM 12-MAY-14 | |
| 1 PL DEC ±0.30 Fractions ±1/64 | | CHECKED: MRF 12-MAY-14 | |
| 2 PL DEC ±0.15 | | ENGINEER: KMM | |
| 3 PL DEC ±0.08 | | APPROVAL: RFC 12-MAY-14 | |
| 3) Note reference = | | CUSTOMER: | |
| MATERIAL SPECIFICATIONS: | | THIS DRAWING IS SUPPLIED FOR INFORMATION ONLY. DESIGN FEATURES, SPECIFICATIONS AND PERFORMANCE DATA SHOWN HEREON ARE THE PROPERTY OF THE AMPHENOL CORPORATION. NO RIGHTS OF REPRODUCTION ARE IMPLIED. ALL DIMENSIONS ARE SUBJECT TO NORMAL MANUFACTURING VARIATIONS. | |
| PROCESS SPECIFICATIONS: | | SIZE | TYPE |
| NEXT ASSY: | | C- | PP29030-Mxxx |
| | | SCALE | REVISION |
| | | FULL | A1 |
| | | C-PP29030 | SHEET 1 OF 1 |

TTM#435 PB LITE, 3 PIN, MALE REC, 10AWG, 1/2-14NPT
 dwg no: C-PP29030-Mxxx
 rev: A1
 sh: 1
 of: 1