

REVISIONS					
REV	ECO	DESCRIPTION	DATE	BY	APPR
A1	-	TECHNICAL DATA SHEET RELEASE	12-MAY-14	KMM	RFC

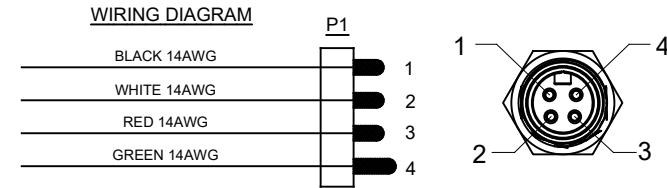
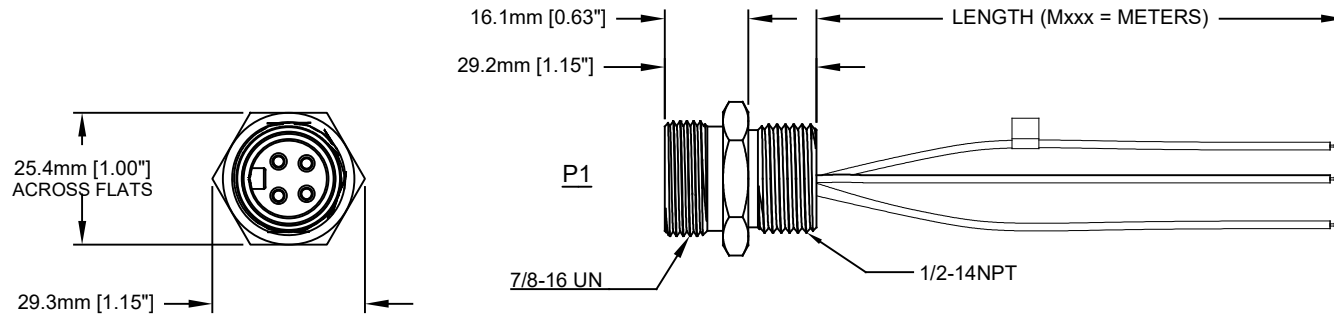

TECHNICAL DATA:

- MATERIALS:**
 HOUSING: MACHINED ALUMINUM, ANODIZED
 INSULATION INSERT: THERMOPLASTIC, UL 94/V-0
 CONTACT: GOLD FLASH PLATING OVER COPPER ALLOY
 CONDUCTOR INSULATION: PVC
 NUMBER OF CONDUCTORS: (4) 14AWG
- ELECTRICAL DATA:**
 CURRENT (MAX): 15A
 VOLTAGE (MAX): 600V AC/DC
 INSULATION RESISTANCE (MIN): 5000M OHMS
 DIELECTRIC TEST VOLTAGE: 2200V
- MECHANICAL DATA:**
 KNOCKOUT HOLE SIZE FOR PANEL MOUNT: 22.2mm [.88"]
 TEMPERATURE RANGE: -40°C TO 90°C
 PROTECTION: IP67 (MATED CONDITION)
 MATING CYCLES: >500
 VIBRATION RESISTANCE PER MIL-STD-202 METHOD 204
 THERMAL SHOCK PER MIL-STD-202 METHOD 207
 48 HOUR SALT SPRAY PER MIL-STD-202 METHOD 101
- RoHS COMPLIANT**
- UL 2237 LISTED ASSEMBLY**
 UL FILE NUMBERS: E339703

TOLERANCE	
0-2.99 M = +100.0/-25.0mm	0-9.99 FT = +4" / -1"
3-8.99 M = +150.0/-25.0mm	10.00-29.99 FT = +6" / -1"
9-14.99 M = +300.0/-25.0mm	30.00-49.99 FT = +12" / -1"
15-OVER M = +450.0/-25.0mm	50 FT-OVER = +18" / -1"

QUANTITY	PART NUMBER	DESCRIPTION	ITEM
MATERIALS LIST			
UNLESS OTHERWISE SPECIFIED		SIGNATURES	DATE
1) All dimensions are in metric (mm).		DRAWN: KMM	12-MAY-14
2) Tolerances are as follows:		CHECKED: MRF	12-MAY-14
1 PL DEC ±0.30 Fractions ±1/64		ENGINEER: KMM	
2 PL DEC ±0.15 Angles ±1°		APPROVAL: RFC	12-MAY-14
3) Note reference =		CUSTOMER:	
MATERIAL SPECIFICATIONS:		THIS DRAWING IS SUPPLIED FOR INFORMATION ONLY. DESIGN FEATURES, SPECIFICATIONS AND PERFORMANCE DATA SHOWN HEREON ARE THE PROPERTY OF THE AMPHENOL CORPORATION. NO RIGHTS OF REPRODUCTION ARE IMPLIED. ALL DIMENSIONS ARE SUBJECT TO NORMAL MANUFACTURING VARIATIONS.	
PROCESS SPECIFICATIONS:		SIZE	TYPE
NEXT ASSY:		C-	p29036-Mxxx
		SCALE	FULL
		DWG NO:	p29036-Mxxx
		REVISION	A1
		SHEET	1 OF 1

TITL#22 PB LITE, 4 PIN, MALE REC., 14AWG, 1/2-14NPT DWG NO: C-29036-Mxxx REV: A1 SH: 1 OF: 1