

**Product Specification**

---

# NHD-320240WG-BxTGH-VZ#-3VR

## Graphic Liquid Crystal Display Module

<b>NHD-</b>	Newhaven Display
<b>320240-</b>	320 x 240 Pixels
<b>WG-</b>	Display Type: Graphic
<b>Bx-</b>	Model
<b>T-</b>	White LED Backlight
<b>G-</b>	STN (+) Gray
<b>H-</b>	Transflective, 6:00 Optimal View, Wide Temperature
<b>VZ#-</b>	Built-in Negative Voltage
<b>3VR-</b>	3.3 Vdd, Frame Ground

## Table of Contents

Document Revision History.....	2
Mechanical Drawing.....	3
Pin Description.....	4
Wiring Diagram.....	4
Electrical Characteristics.....	5
Optical Characteristics.....	5
Jumper Selection.....	5
Controller Information.....	5
Table of Commands.....	6
Timing Characteristics.....	9
Example Initialization Code.....	11
Quality Information.....	13

---

## Additional Resources

- **Support Forum:** <https://support.newhavendisplay.com/hc/en-us/community/topics>
- **GitHub:** <https://github.com/newhavendisplay>
- **Example Code:** <https://support.newhavendisplay.com/hc/en-us/categories/4409527834135-Example-Code/>
- **Knowledge Center:** [https://www.newhavendisplay.com/knowledge\\_center.html](https://www.newhavendisplay.com/knowledge_center.html)
- **Quality Center:** [https://www.newhavendisplay.com/quality\\_center.html](https://www.newhavendisplay.com/quality_center.html)
- **Precautions for using LCDs/LCMs:** <https://www.newhavendisplay.com/specs/precautions.pdf>
- **Warranty / Terms & Conditions:** <https://www.newhavendisplay.com/terms.html>



## Document Revision History

Revision	Date	Description	Changed By
0	06/07/2007	Initial Release	-
1	03/16/2010	User Guide Reformat	MC
2	09/02/2010	Mechanical Drawing Update	MP
3	10/09/2013	Mechanical Drawing, Pin Description, Electrical characteristics, Timing Characteristics updated, Added Jumper Selection	ML
4	06/01/2016	Mechanical Drawing, Pin Description, Quality Info, Electrical Characteristics, Optical Characteristics	TM
5	02/10/2017	IDD & ILED Updated	SB
6	02/26/2021	LCD Glass Panel Upgraded; Updated Contrast Condition & Quality Information Part Revision Upgraded to Rev1A	AS
7	05/01/2023	Updated Backlight Driven Condition	KL
8	11/03/2023	Minimum Backlight Current Updated from 40mA to 96mA	KL
9	06/10/2024	Mechanical Drawing Updated	KL

# Mechanical Drawing

**Newhaven Display**

NHD-320240WG-BxTGH-VZ#\_Rev1A

Date Code

Part Label (type/format may vary)

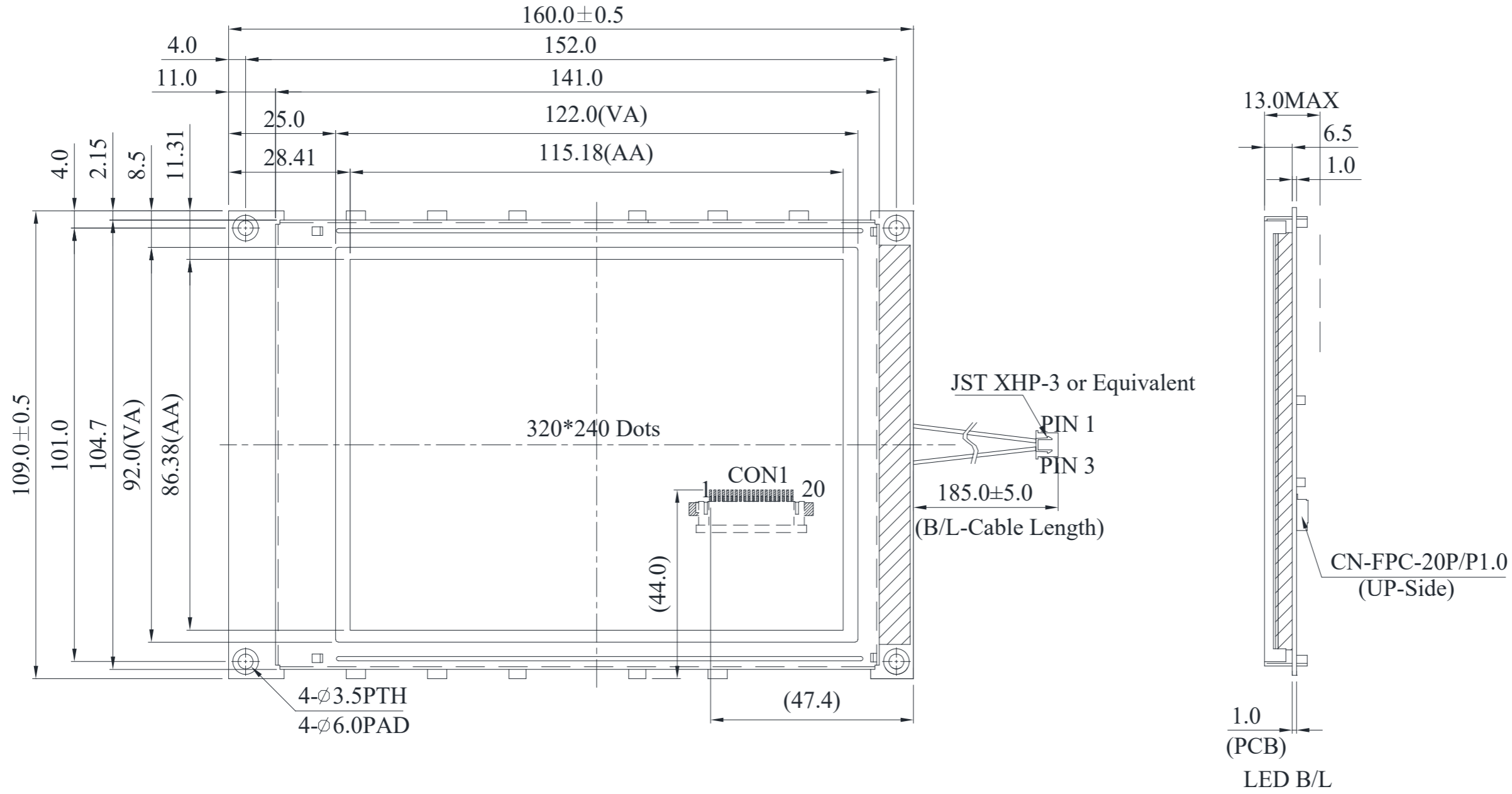

Pin No.	Symbol
1	Vss
2	Vdd
3	Vo
4	A0
5	WR
6	RD
7	DB0
8	DB1
9	DB2
10	DB3
11	DB4
12	DB5
13	DB6
14	DB7
15	CS
16	RES
17	Vee
18	NC
19	FG
20	WAIT

Product Description: 320x240 Graphic LCD

1. Driver IC: S1D13700
2. Driving Mode: 1/240 Duty
3. Interface: 8-bit 8080 Parallel
4. Power Requirement: 3.3V LCD
5. Optical Features: STN (+) Gray, Transflective, 6:00 View, White Backlight
6. Recommended FFC Connector: 20pin 1.0mm pitch

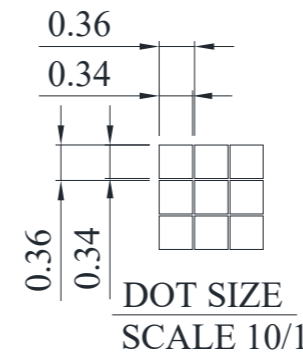

<b>Standard Tolerance:</b> (Unless otherwise specified)  Linear: ±0.3mm		
	Drawing/Part Number: <b>NHD-320240WG-BxTGH-VZ#-3VR</b>	Revision: <b>1A</b>
<b>Unless otherwise specified:</b> • Dimensions are in Millimeters • Third Angle Projection	Drawn By: K. Lewis	Approved By: K. Lewis
	Drawn Date: 06/10/2024	Approved Date: 06/10/2024
This drawing is solely the property of Newhaven Display International, Inc. The information it contains is not to be disclosed, reproduced or copied in whole or part without written approval from Newhaven Display.		

## Pin Description

Pin No.	Symbol	External Connection	Function Description
1	V <sub>SS</sub>	Power Supply	Ground
2	V <sub>DD</sub>	Power Supply	Supply Voltage for Logic (+3.3V)
3	V <sub>0</sub>	Adj. Power Supply	Supply Voltage for contrast (approx. -18.8V)
4	A0	MPU	Register Select signal. A0=1: Command, A0=0: Data
5	/WR R/W	MPU	8080: Active LOW Write signal 6800: Read/Write select signal, R/W=1: Read R/W=0: Write
6	/RD E	MPU	8080: Active LOW Read signal 6800: Operation Enable signal. Falling edge triggered.
7-14	DB0-DB7	MPU	8-bit bi-directional data bus
15	/CS	MPU	Active LOW Chip Select signal
16	/RESET	MPU	Active LOW Reset signal
17	VEE	Power Supply	Negative voltage output (-25V)
18	NC	-	No Connect
19	NC	-	No Connect
20	NC	-	No Connect

**Recommended LCD connector:** 20 pin FFC connector, 1.0mm pitch pins

**Backlight connector:** JST p/n: XHP-3

**Mates with:** JST p/n: B 3B-XH-A

## Wiring Diagram

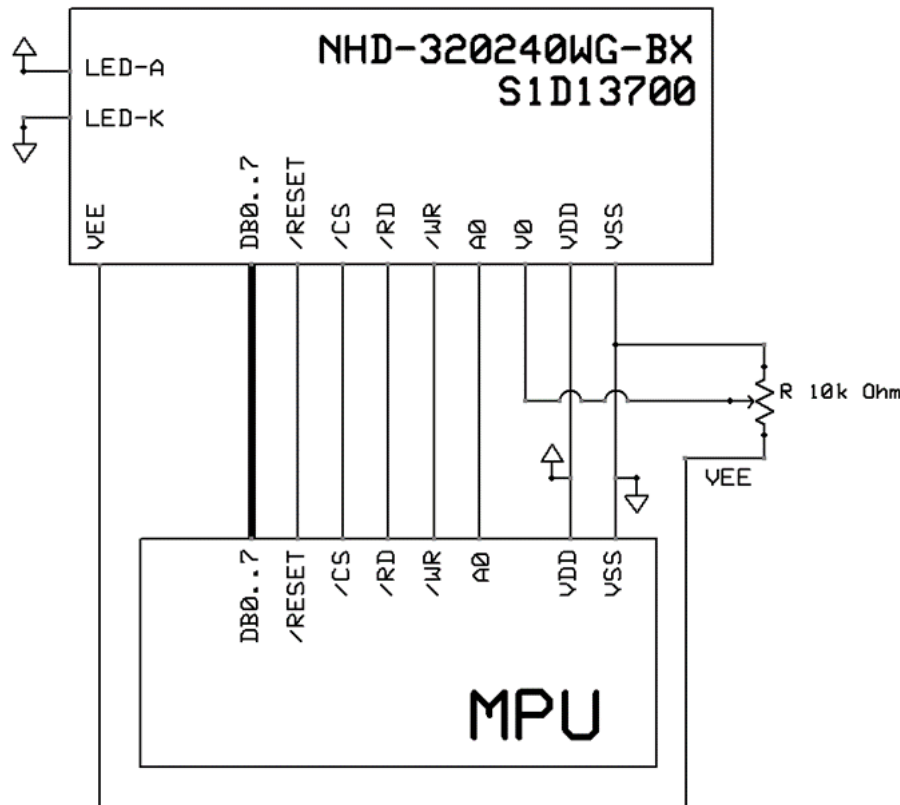

## Electrical Characteristics

Item	Symbol	Condition	Min.	Typ.	Max.	Unit
Operating Temperature Range	T <sub>OP</sub>	Absolute Max	-20	-	+70	°C
Storage Temperature Range	T <sub>ST</sub>	Absolute Max	-30	-	+80	°C
Supply Voltage	V <sub>DD</sub>	-	3.0	3.3	3.6	V
Supply Current	I <sub>DD</sub>	V <sub>DD</sub> = 3.3V	50	100	150	mA
Supply for LCD (Contrast)	V <sub>LCD</sub>	T <sub>OP</sub> = 25°C	23.0	23.6	24.2	V
"H" Level input	V <sub>IH</sub>	-	2.0	-	V <sub>DD</sub>	V
"L" Level input	V <sub>IL</sub>	-	GND	-	0.8	V
"H" Level output	V <sub>OH</sub>	-	V <sub>DD</sub> - 0.4	-	V <sub>DD</sub>	V
"L" Level output	V <sub>OL</sub>	-	V <sub>SS</sub>	-	0.4	V
Backlight Supply Voltage	V <sub>LED</sub>	-	3.4	3.5	3.6	V
Backlight Supply Current	I <sub>LED</sub>	V <sub>LED</sub> = 3.5V	96	128	160	mA
Backlight Lifetime	-	I <sub>LED</sub> = 128mA T <sub>OP</sub> = 25°C	-	50,000	-	Hrs.

\*The LED of the backlight is driven by current drain; drive voltage is for reference only. Drive voltage must be selected to ensure backlight current drain is below MAX level stated.

## Optical Characteristics

Item	Symbol	Condition	Min.	Typ.	Max.	Unit
Viewing Angle – Top	φY+	Cr ≥ 2	-	20	-	°
Viewing Angle – Bottom	φY-		-	40	-	°
Viewing Angle – Left	θX-		-	30	-	°
Viewing Angle – Right	θX+		-	30	-	°
Contrast Ratio	Cr	-	-	3	-	-
Response Time (rise)	Tr	-	-	200	300	ms
Response Time (fall)	Tf	-	-	250	350	ms

## Jumper Selection

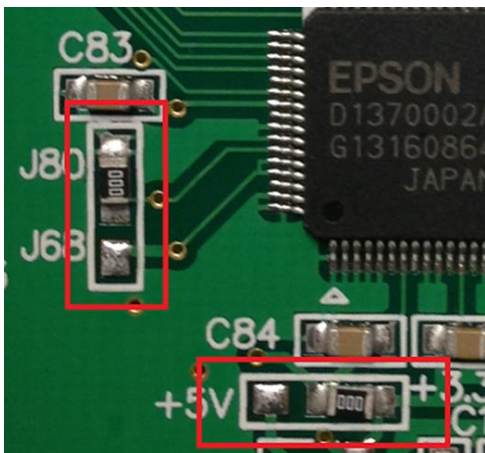

Note: This display is pre-configured for 3.3V and 8080 mode.

## Controller Information

Built-in S1D13700 Controller: <https://support.newhavendisplay.com/hc/en-us/articles/4414798665367--S1D13700>

## Table of Commands

<b>REG[01h] Horizontal Character Size Register</b>							
Address = 8001h    Default = 00h							
Read/Write							
MOD	n/a			Horizontal Character Size bits 3-0			
7	6	5	4	3	2	1	0
<b>REG[02h] Vertical Character Size Register</b>							
Address = 8002h    Default = 00h							
Read/Write							
n/a			Vertical Character Size bits 3-0				
7	6	5	4	3	2	1	0
<b>REG[03h] Character Bytes Per Row Register</b>							
Address = 8003h    Default = 00h							
Read/Write							
Character Bytes Per Row bits 7-0							
7	6	5	4	3	2	1	0
<b>REG[04h] Total Character Bytes Per Row Register</b>							
Address = 8004h    Default = 00h							
Read/Write							
Total Character Bytes Per Row bits 7-0							
7	6	5	4	3	2	1	0
<b>REG[05h] Frame Height Register</b>							
Address = 8005h    Default = 00h							
Read/Write							
Frame Height bits 7-0							
7	6	5	4	3	2	1	0
<b>REG[06h] Horizontal Address Range Register 0</b>							
Address = 8006h    Default = 00h							
Read/Write							
Horizontal Address Range bits 7-0							
7	6	5	4	3	2	1	0
<b>REG[07h] Horizontal Address Range Register 1</b>							
Address = 8007h    Default = 00h							
Read/Write							
Horizontal Address Range bits 15-8							
7	6	5	4	3	2	1	0
<b>REG[08h] Power Save Mode Register</b>							
Address = 8008h    Default = 01h							
Read/Write							
n/a							Power Save Mode Enable
7	6	5	4	3	2	1	0
<b>REG[09h] Display Enable Register</b>							
Address = 8009h    Default = 00h							
Read/Write							
n/a							Display Enable
7	6	5	4	3	2	1	0
<b>REG[0Ah] Display Attribute Register</b>							
Address = 800Ah    Default = 00h							
Read/Write							
SAD3 Attribute bits 1-0		SAD2 Attribute bits 1-0		SAD1 Attribute bits 1-0		Cursor Attribute bits 1-0	
7	6	5	4	3	2	1	0
<b>REG[0Bh] Screen Block 1 Start Address Register 0</b>							
Address = 800Bh    Default = 00h							
Read/Write							
Screen Block 1 Start Address bits 7-0 (LSB)							
7	6	5	4	3	2	1	0
<b>REG[0Ch] Screen Block 1 Start Address Register 1</b>							
Address = 800Ch    Default = 00h							
Read/Write							
Screen Block 1 Start Address bits 15-8 (MSB)							
7	6	5	4	3	2	1	0
<b>REG[0Dh] Screen Block 1 Size Register</b>							
Address = 800Dh    Default = 00h							
Read/Write							
Screen Block 1 Size bits 7-0							
7	6	5	4	3	2	1	0
<b>REG[0Eh] Screen Block 2 Start Address Register 0</b>							
Address = 800Eh    Default = 00h							
Read/Write							
Screen Block 2 Start Address bits 7-0 (LSB)							
7	6	5	4	3	2	1	0



<b>REG[0Fh] Screen Block 2 Start Address Register 1</b>							
Address = 800Fh    Default = 00h							
Read/Write							
Screen Block 2 Start Address bits 15-8 (MSB)							
7	6	5	4	3	2	1	0
<b>REG[10h] Screen Block 2 Size Register</b>							
Address = 8010h    Default = 00h							
Read/Write							
Screen Block 2 Size bits 7-0							
7	6	5	4	3	2	1	0
<b>REG[11h] Screen Block 3 Start Address Register 0</b>							
Address = 8011h    Default = 00h							
Read/Write							
Screen Block 3 Start Address bits 7-0 (LSB)							
7	6	5	4	3	2	1	0
<b>REG[12h] Screen Block 3 Start Address Register 1</b>							
Address = 8012h    Default = 00h							
Read/Write							
Screen Block 3 Start Address bits 15-8 (MSB)							
7	6	5	4	3	2	1	0
<b>REG[13h] Screen Block 4 Start Address Register 0</b>							
Address = 8013h    Default = 00h							
Read/Write							
Screen Block 4 Start Address bits 7-0 (LSB)							
7	6	5	4	3	2	1	0
<b>REG[14h] Screen Block 4 Start Address Register 1</b>							
Address = 8014h    Default = 00h							
Read/Write							
Screen Block 4 Start Address bits 15-8 (MSB)							
7	6	5	4	3	2	1	0
<b>REG[15h] Cursor Width Register</b>							
Address = 8015h    Default = 00h							
Read/Write							
n/a				Cursor Width bits 3-0			
7	6	5	4	3	2	1	0
<b>REG[16h] Cursor Height Register</b>							
Address = 8016h    Default = 00h							
Read/Write							
Cursor Mode	n/a			Cursor Height bits 3-0			
7	6	5	4	3	2	1	0
<b>REG[17h] Cursor Shift Direction Register</b>							
Address = 8017h    Default = 00h							
Read/Write							
n/a					Cursor Shift Direction bits 1-0		
7	6	5	4	3	2	1	0
<b>REG[18h] Overlay Register</b>							
Address = 8018h    Default = 00h							
Read/Write							
n/a			3 Layer Overlay Select	Screen Block 3 Display Mode	Screen Block 1 Display Mode	Layer Composition Method bits 1-0	
7	6	5	4	3	2	1	0
<b>REG[19h] Character Generator RAM Start Address Register 0</b>							
Address = 8019h    Default = 00h							
Read/Write							
CGRAM Start Address bits 7-0 (LSB)							
7	6	5	4	3	2	1	0
<b>REG[1Ah] Character Generator RAM Start Address Register 1</b>							
Address = 801Ah    Default = 00h							
Read/Write							
CGRAM Start Address bits 15-8 (MSB)							
7	6	5	4	3	2	1	0
<b>REG[1Bh] Horizontal Pixel Scroll Register</b>							
Address = 801Bh    Default = 00h							
Read/Write							
n/a				Horizontal Pixel Scroll bits 2-0			
7	6	5	4	3	2	1	0
<b>REG[1Ch] Cursor Write Register 0</b>							
Address = 801Ch    Default = 00h							
Write Only							
Cursor Write bits 7-0 (LSB)							
7	6	5	4	3	2	1	0



<b>REG[1Dh] Cursor Write Register 1</b>								Write Only
Address = 801Dh    Default = 00h								
Cursor Write bits 15-8 (MSB)								
7	6	5	4	3	2	1	0	
<b>REG[1Eh] Cursor Read Register 0</b>								Read Only
Address = 801Eh    Default = 00h								
Cursor Read bits 7-0 (LSB)								
7	6	5	4	3	2	1	0	
<b>REG[1Fh] Cursor Read Register 1</b>								Read Only
Address = 801Fh    Default = 00h								
Cursor Read bits 15-8 (MSB)								
7	6	5	4	3	2	1	0	
<b>REG[20h] Bit-Per-Pixel Select Register</b>								Read/Write
Address = 8020h    Default = 00h								
n/a						Bit-Per-Pixel Select bits 1-0		
7	6	5	4	3	2	1	0	

# Timing Characteristics

## 8080 Family Bus Interface Timing

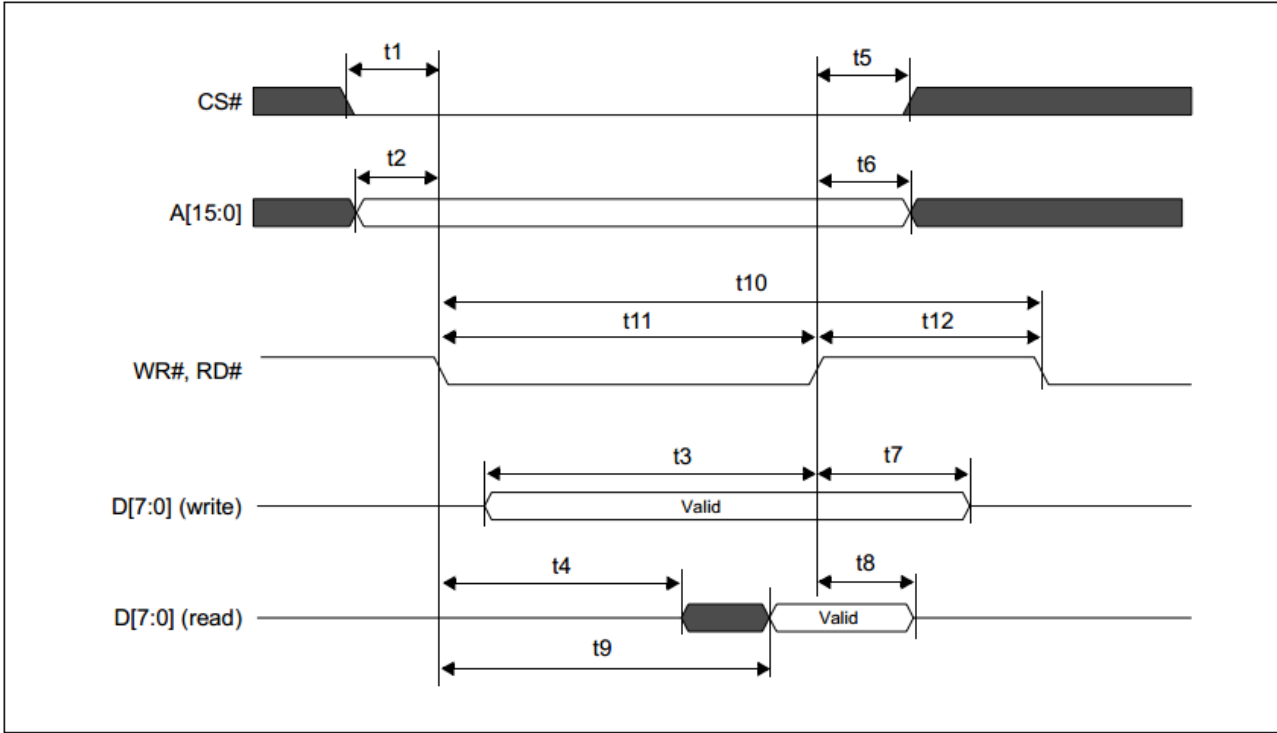

Symbol	Parameter	3.3 Volt		5.0 Volt		Units
		Min	Max	Min	Max	
t1	CS# setup time	5	—	5	—	ns
t2	A[15:0] setup time	5	—	5	—	ns
t3	D[7:0] setup time to WR# rising edge (write cycle)	Note 2	—	Note 2	—	ns
t4	RD# falling edge to D[7:0] driven (read cycle)	3	—	3	—	ns
t5	CS# hold time	7	—	7	—	ns
t6	A[15:0] hold time	7	—	7	—	ns
t7	D[7:0] hold time from WR# rising edge (write cycle)	5	—	5	—	ns
t8	D[7:0] hold time from RD# rising edge (read cycle)	3	14	3	14	ns
t9	RD# falling edge to valid Data (read cycle)	—	Note 3	—	Note 3	ns
t10	RD#, WR# cycle time	Note 4	—	Note 4	—	ns
t11	RD#, WR# pulse active time	5	—	5	—	Ts
t12	RD#, WR# pulse inactive time	Note 5	—	Note 5	—	ns

1. Ts = System clock period
2. t3min = 2Ts + 5
3. t9max = 4Ts + 18 (for 3.3V)  
= 4Ts + 20 (for 5.0V)
4. t10min = 6Ts (for a read cycle followed by a read or write cycle)  
= 7Ts + 2 (for a write cycle followed by a write cycle)  
= 10Ts + 2 (for a write cycle followed by a read cycle)
5. t12min = 1Ts (for a read cycle followed by a read or write cycle)  
= 2Ts + 2 (for a write cycle followed by a write cycle)  
= 5Ts + 2 (for a write cycle followed by a read cycle)

## 6800 Family Bus Interface Timing

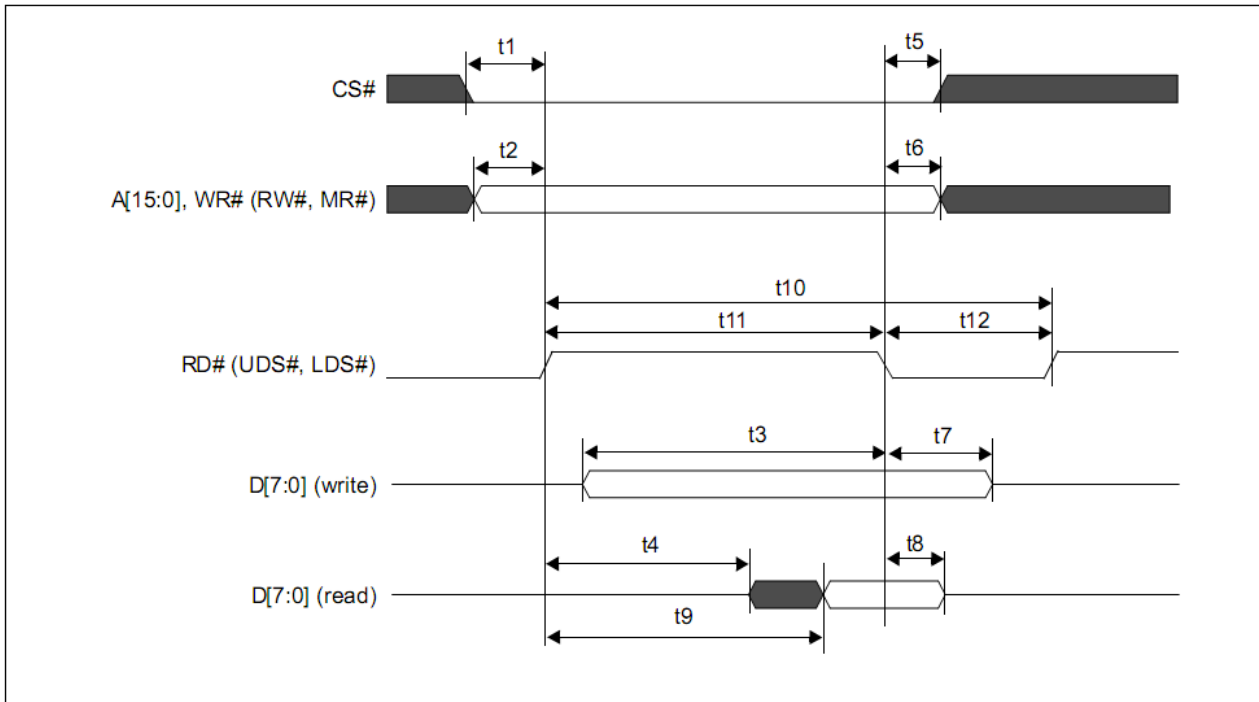

Symbol	Parameter	3.3 Volt		5.0 Volt		Units
		Min	Max	Min	Max	
t1	CS# setup time	5	—	5	—	ns
t2	A[15:0] setup time	5	—	5	—	ns
t3	D[7:0] setup time to RD# falling edge (write cycle)	Note 2	—	Note 2	—	ns
t4	RD# rising edge to D[7:0] driven (read cycle)	3	—	3	—	ns
t5	CS# hold time	7	—	7	—	ns
t6	A[15:0] hold time	7	—	7	—	ns
t7	D[7:0] hold time from RD# falling edge (write cycle)	5	—	5	—	ns
t8	D[7:0] hold time from RD# falling edge (read cycle)	2	55	2	55	ns
t9	RD# rising edge to valid Data	—	Note 3	—	Note 3	ns
t10	RD# cycle time	Note 4	—	Note 4	—	ns
t11	RD# pulse active time	5	—	5	—	Ts
t12	RD# pulse inactive time	Note 5	—	Note 5	—	ns

1.  $T_s$  = System clock period
2.  $t_{3min}$  =  $2T_s + 5$
3.  $t_{9max}$  =  $4T_s + 18$  (for 3.3V)  
=  $4T_s + 20$  (for 5.0V)
4.  $t_{10min}$  =  $6T_s$  (for a read cycle followed by a read or write cycle)  
=  $7T_s + 2$  (for a write cycle followed by a write cycle)  
=  $10T_s + 2$  (for a write cycle followed by a read cycle)
5.  $t_{12min}$  =  $1T_s$  (for a read cycle followed by a read or write cycle)  
=  $2T_s + 2$  (for a write cycle followed by a write cycle)  
=  $5T_s + 2$  (for a write cycle followed by a read cycle)

## Example Initialization Code

```
//-----
Sub Writecom
  Set P3.0
  P1 = A
  Reset P3.1
  Reset P3.7
  Set P3.4
  Reset P3.4
  Set P3.7
  Set P3.1
End Sub

Sub Writedata
  Reset P3.0
  P1 = A
  Reset P3.1
  Reset P3.7
  Set P3.4
  Reset P3.4
  Set P3.7
  Set P3.1
End Sub

//-----

Sub Init
  Set P3.2
  Reset P3.6
  Waitms 10
  Set P3.6
  Waitms 100

  A = &H40
  Call Writecom
  A = &H30
  Call Writedata
  A = &H87
  Call Writedata
  A = &H07
  Call Writedata
  A = &H27
  Call Writedata
  A = &H50
  Call Writedata
  A = &HEF
  Call Writedata
  A = &H28
  Call Writedata
  A = &H00
  Call Writedata
  A = &H44
  Call Writecom
  A = &H00
  Call Writedata
  A = &H00
  Call Writedata
  A = &HEF
  Call Writedata
  A = &HB0
  Call Writedata
  A = &H04
  Call Writedata
  A = &HEF
  Call Writedata

  'A0 = H = Write command
  'move data to P1
  'chip select
  'R/W
  'E
  'E
  'R/W
  'CS

  'A0 = L = Write data

  'SEL=1 = Motorola 6800 interface
  'RESET
  'wait
  'RESET done
  'wait

  'system set command
  'set parameters
  'horizontal character size=8
  'vertical character size=8
  'display addresses per line
  'total address range per line
  '240 display lines
  'virtual address1
  'virtual address2
  'scroll
  'start address1
  'start address2
  '240 lines
  '2nd screen start1
  '2nd screen start2
  '2nd screen 240 lines

```



```
A = &H00
Call Writedata
A = &H00
Call Writedata
A = &H00
Call Writedata
A = &H00
Call Writedata
A = &H5A
Call Writecom
A = &H00
Call Writedata
A = &H5B
Call Writecom
A = &H00
Call Writedata
A = &H5D
Call Writecom
A = &H04
Call Writedata
A = &H86
Call Writedata
A = &H4C
Call Writecom

Call Clr

A = &H59
Call Writecom
A = &H14
Call Writedata
End Sub
```

```
'3rd screen address1
'3rd screen address2
'4th screen address1
'4th screen address2
'hdot scr
'horizontal pixel shift=0
'overlay
'OR
'cursor form
'5 pixels
'by 7 pixels
'cursor direction = right

'clear the screen
'disp on/off
'on
```

//-----

## Quality Information

Test Item	Content of Test	Test Condition	Note
High Temperature storage	Endurance test applying the high storage temperature for a long time.	+80°C , 200hrs	2
Low Temperature storage	Endurance test applying the low storage temperature for a long time.	-30°C , 200hrs	1,2
High Temperature Operation	Endurance test applying the electric stress (voltage & current) and the high thermal stress for a long time.	+70°C 200hrs	2
Low Temperature Operation	Endurance test applying the electric stress (voltage & current) and the low thermal stress for a long time.	-20°C , 200hrs	1,2
High Temperature / Humidity Storage	Endurance test applying the electric stress (voltage & current) and the high thermal with high humidity stress for a long time.	+60°C , 90% RH , 96hrs	1,2
Thermal Shock resistance	Endurance test applying the electric stress (voltage & current) during a cycle of low and high thermal stress.	-20°C,30min -> 25°C,5min - >70°C,30min = 1 cycle 10 cycles	
Vibration test	Endurance test applying vibration to simulate transportation and use.	10-55Hz, 1.5mm amplitude. 60 sec in each of 3 directions X,Y,Z For 15 minutes	3
Static electricity test	Endurance test applying electric static discharge.	Air: ±800V 150pF/330Ω, 5 Times	
		Contact: ±600V 150pF/330Ω, 5 Times	

**Note 1:** No condensation to be observed.

**Note 2:** Conducted after 4 hours of storage at 25°C, 0%RH.

**Note 3:** Test performed on product itself, not inside a container.