

Product Specification

NHD-1.8-128160EF-CTXI#-T

TFT (Thin-Film Transistor) Liquid Crystal Display Module

NHD-	Newhaven Display
1.8-	1.8" Diagonal
128160-	128 x 160 Pixels (Portrait Mode)
EF-	Model
C-	Built-in Controller
T-	White LED Backlight
X -	TFT
I-	6:00 Optimal View, Wide Temperature
#-	RoHS Compliant
T-	4-wire Resistive Touch Panel

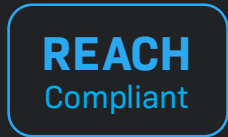

Table of Contents

Document Revision History.....	2
Mechanical Drawing.....	3
Pin Description.....	4
Wiring Diagram.....	4
Electrical Characteristics.....	5
Optical Characteristics.....	5
Touch Panel Characteristics.....	5
Controller Information.....	5
Table of commands.....	6
Timing Characteristics.....	6
Example Program Code.....	9
Quality Information.....	10

Additional Resources

- **Support Forum:** <https://support.newhavendisplay.com/hc/en-us/community/topics>
- **GitHub:** <https://github.com/newhavendisplay>
- **Example Code:** <https://support.newhavendisplay.com/hc/en-us/categories/4409527834135-Example-Code/>
- **Knowledge Center:** https://www.newhavendisplay.com/knowledge_center.html
- **Quality Center:** https://www.newhavendisplay.com/quality_center.html
- **Precautions for using LCDs/LCMs:** <https://www.newhavendisplay.com/specs/precautions.pdf>
- **Warranty / Terms & Conditions:** <https://www.newhavendisplay.com/terms.html>



Document Revision History

Revision	Date	Description	Changed By
0	09/11/2013	Initial Release	AK
1	11/06/2015	Datasheet Reformat	SB
2	09/26/2018	Backlight Characteristics & Supply Current Updated	SB
3	03/21/2019	Driver Updated from ILI9163C to ILI9163V	SB
4	01/13/2021	Updated 2D Mechanical Drawing & Quality Information	AS
5	03/08/2021	2D Mechanical Drawing Redesign; Updated Typical Backlight Voltage, Optical Characteristics & Quality Information	AS
6	12/05/2022	Document Formatting Updated	KL
7	08/07/2023	Timing Characteristics and Table of Commands Updated	KL
8	09/05/2023	V _{DD} /IOV _{DD} Supply Voltage Updated from 2.8V to 3.0V (Typ.) Mechanical Drawing Updated	KL
9	03/27/2024	Date Code Updated on Mechanical Drawing	KL

Mechanical Drawing

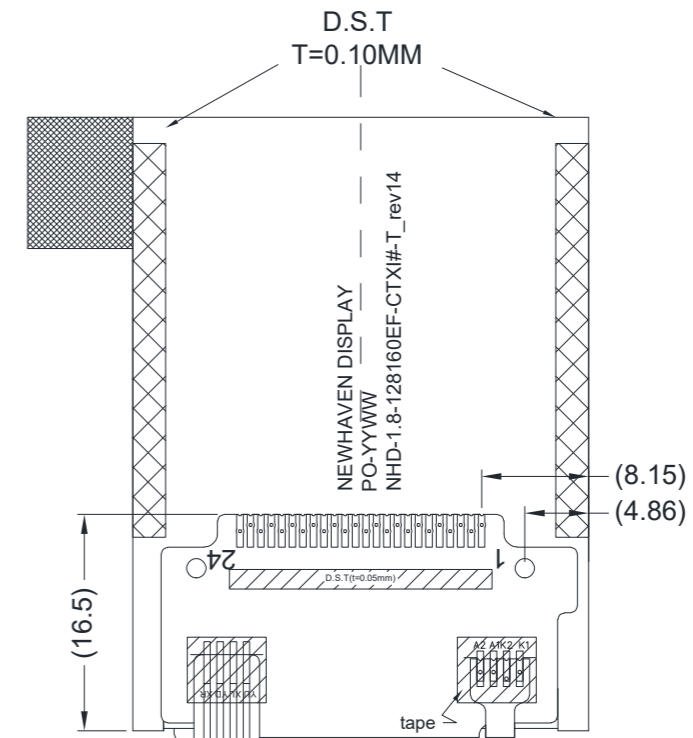
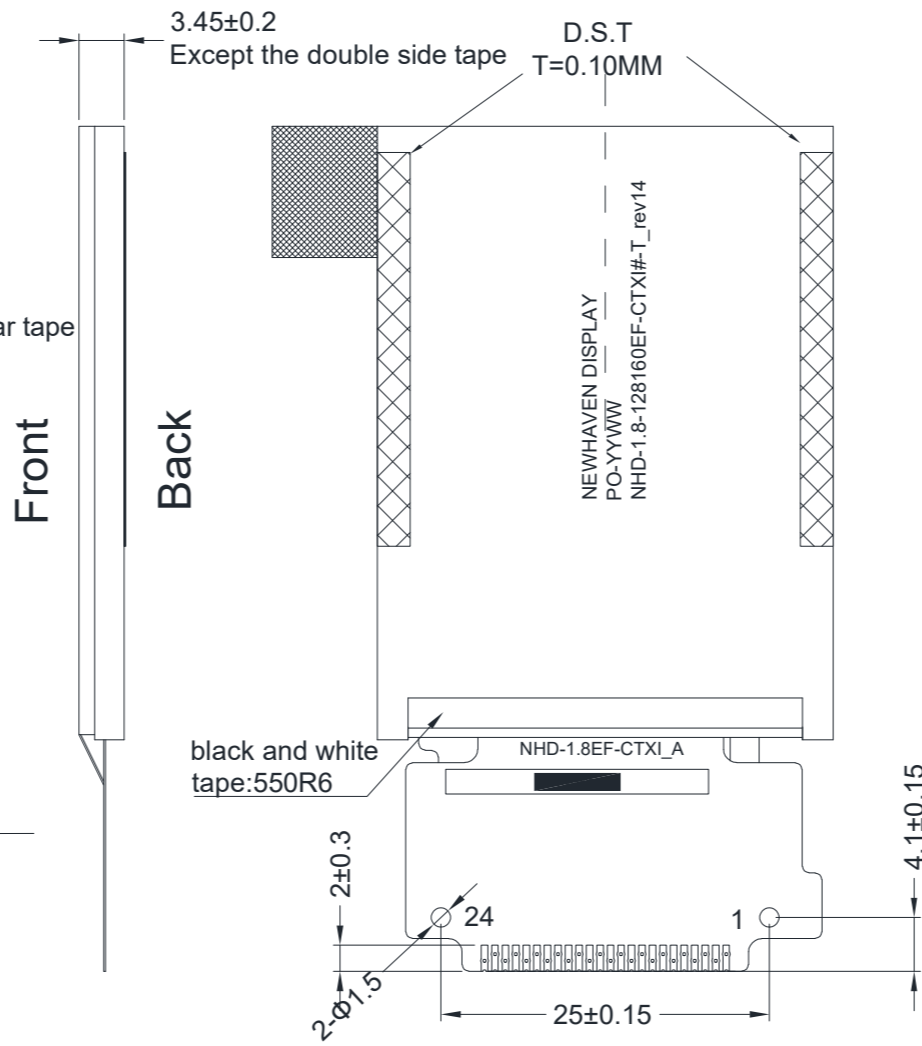
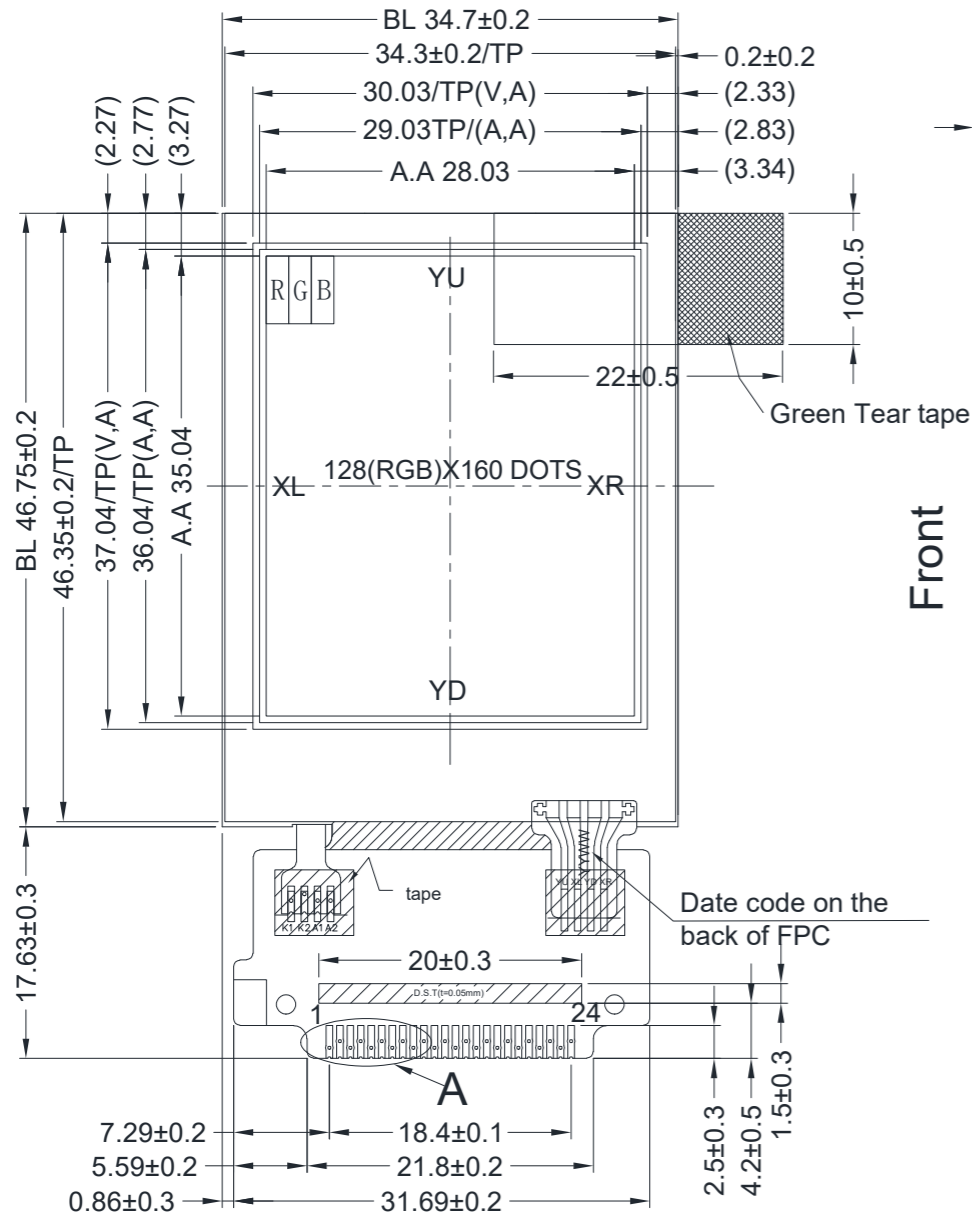

No:	PIN NAME
1	GND
2	IOVCC 1.8V
3	VCC 2.8V
4	CSB
5	RST
6	RS
7	WRB
8	RDB
9	DB0
10	DB1
11	DB2
12	DB3
13	DB4
14	DB5
15	DB6
16	DB7
17	BL_A
18	BL_K1
19	BL_K2
20	GND
21	YU
22	XL
23	YD
24	XR

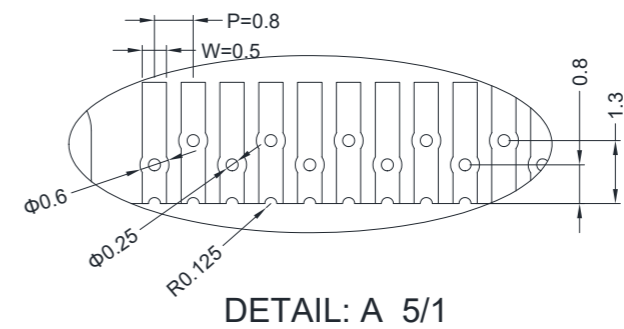
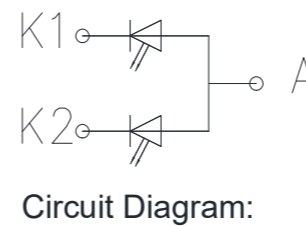

- Product Description: 1.8" 128x160 TFT w/ Resistive Touch
1. Driver IC: ILI9163V
 2. Interface: 8-bit Parallel TFT, 4-wire RTP
 3. Power Requirement: 3.0V TFT, 3.2V/30mA Backlight
 4. Optical Features: Normally White, Transmissive, Anti-Glare, 280cd/m²

Standard Tolerance: (Unless otherwise specified) Linear: ±0.3mm		
	Drawing/Part Number: NHD-1.8-128160EF-CTXI#-T	Revision: 14
Unless otherwise specified: • Dimensions are in Millimeters • Third Angle Projection	Drawn By: K. Lewis	Approved By: K. Lewis
	Drawn Date: 03/27/2024	Approved Date: 03/27/2024
This drawing is solely the property of Newhaven Display International, Inc. The information it contains is not to be disclosed, reproduced or copied in whole or part without written approval from Newhaven Display.		

Pin Description

Pin No.	Symbol	External Connection	Function Description
1	GND	Power Supply	Ground
2	IOVDD	Power Supply	Supply Voltage for Logic (3.0V) – Can be tied to VDD
3	VDD	Power Supply	Power Supply for LCD (3.0V)
4	/CS	MPU	Active LOW Chip Select signal
5	/RST	MPU	Active LOW Reset signal
6	D/C	MPU	Data / Command selection: '1' = Data ; '0' = Command
7	/WR	MPU	Active LOW Write signal
8	/RD	MPU	Active LOW Read signal
9	DB0	MPU	8-bit bi-directional data bus
10	DB1	MPU	
11	DB2	MPU	
12	DB3	MPU	
13	DB4	MPU	
14	DB5	MPU	
15	DB6	MPU	
16	DB7	MPU	
17	LED-A	Power Supply	Backlight Anode (30mA @ 3.2V)
18	LED-K1	Power Supply	Backlight Cathode (Ground)
19	LED-K2	Power Supply	Backlight Cathode (Ground)
20	GND	Power Supply	Ground
21	YU	Touch Controller	Touch Panel Up
22	XL	Touch Controller	Touch Panel Left
23	YD	Touch Controller	Touch Panel Down
24	XR	Touch Controller	Touch Panel Right

LCD connector: Hot-bar solder directly to PCB

Wiring Diagram

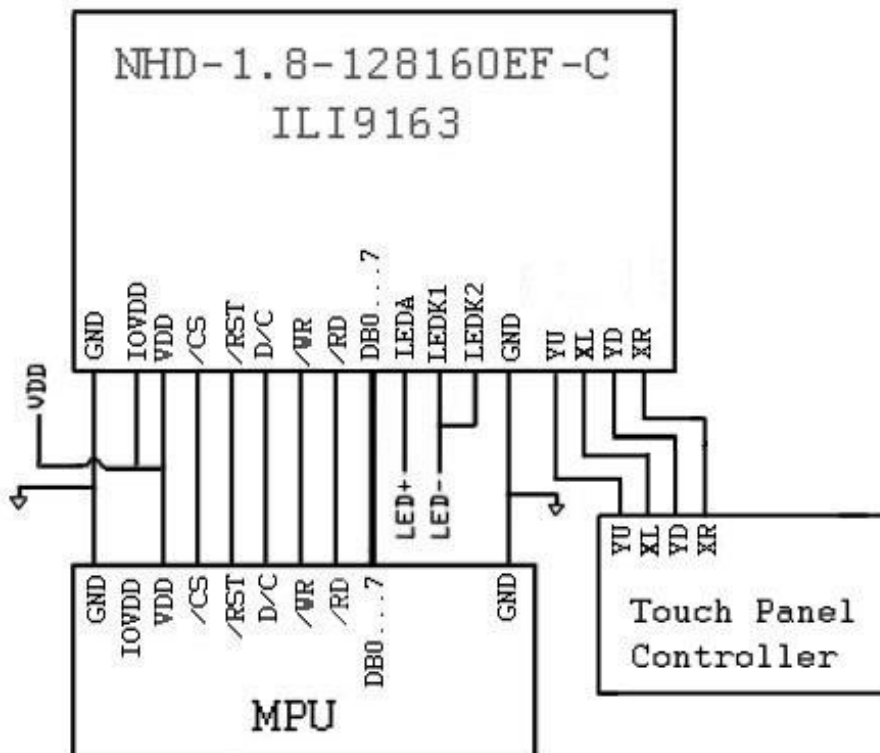

Electrical Characteristics

Item	Symbol	Condition	Min.	Typ.	Max.	Unit
Operating Temperature Range	T _{OP}	Absolute Max	-20	-	+70	°C
Storage Temperature Range	T _{ST}	Absolute Max	-30	-	+80	°C
Supply Voltage for Logic	IOV _{DD}	-	1.65	3.0	3.3	V
Supply Voltage for LCD	V _{DD}	-	2.5	3.0	3.3	V
Supply Current	I _{DD}	-	1	3	5	mA
"H" Level input	I _{DD}	-	0.7*IOV _{DD}	-	IOV _{DD}	V
"L" Level input	V _{IH}	-	GND	-	0.3*IOV _{DD}	V
"H" Level output	V _{IL}	-	0.8*IOV _{DD}	-	IOV _{DD}	V
"L" Level output	V _{OH}	-	GND	-	0.2*IOV _{DD}	V
Backlight Supply Current	I _{LED}	-	-	30	40	mA
Backlight Supply Voltage	V _{LED}	I _{LED} = 30mA	2.8	3.2	3.3	V
Backlight Lifetime*	-	I _{LED} = 30 mA T _{OP} = 25°C	20,000	50,000	-	Hrs.

*Backlight lifetime is rated as Hours until **half-brightness**, under normal operating conditions. The LED of the backlight is driven by current drain; drive voltage is for reference only. Drive voltage must be selected to ensure backlight current drain is below MAX level stated.

Optical Characteristics

Item	Symbol	Condition	Min.	Typ.	Max.	Unit
Optimal Viewing Angle	Top	CR ≥ 10	-	60	-	°
	Bottom		-	40	-	°
	Left		-	60	-	°
	Right		-	60	-	°
Contrast Ratio	CR	-	400	500	-	-
Luminance	L _V	I _{LED} = 30mA	220	280	-	cd/m ²
Response Time (Rise + Fall)	T _R +T _F	T _{OP} = 25°C	-	8	16	ms

Touch Panel Characteristics

Item	Min.	Typ.	Max.	Unit
Linearity	-1.5	-	1.5	%
Circuit Resistance – X-Axis	150	-	550	Ω
Circuit Resistance – Y-Axis	250	-	800	Ω
Insulation Resistance	20	-	-	MΩ
Operating Voltage	-	5	10	V
Chattering	-	-	10	ms
Activation Force	20	-	80	g
Pen Writing Durability	100,000	-	-	Characters
Pitting Durability	1,000,000	-	-	Touches
Surface Hardness	3	-	-	H

Controller Information

Built-in ILI9163V Controller: <https://support.newhavendisplay.com/hc/en-us/articles/4414575853079--ILI9163V>



Table of commands

For Command Table and Descriptions, please see:

https://support.newhavendisplay.com/hc/en-us/article_attachments/4414532035607/ILI9163V.pdf

Timing Characteristics

Parallel 8-bit Bus

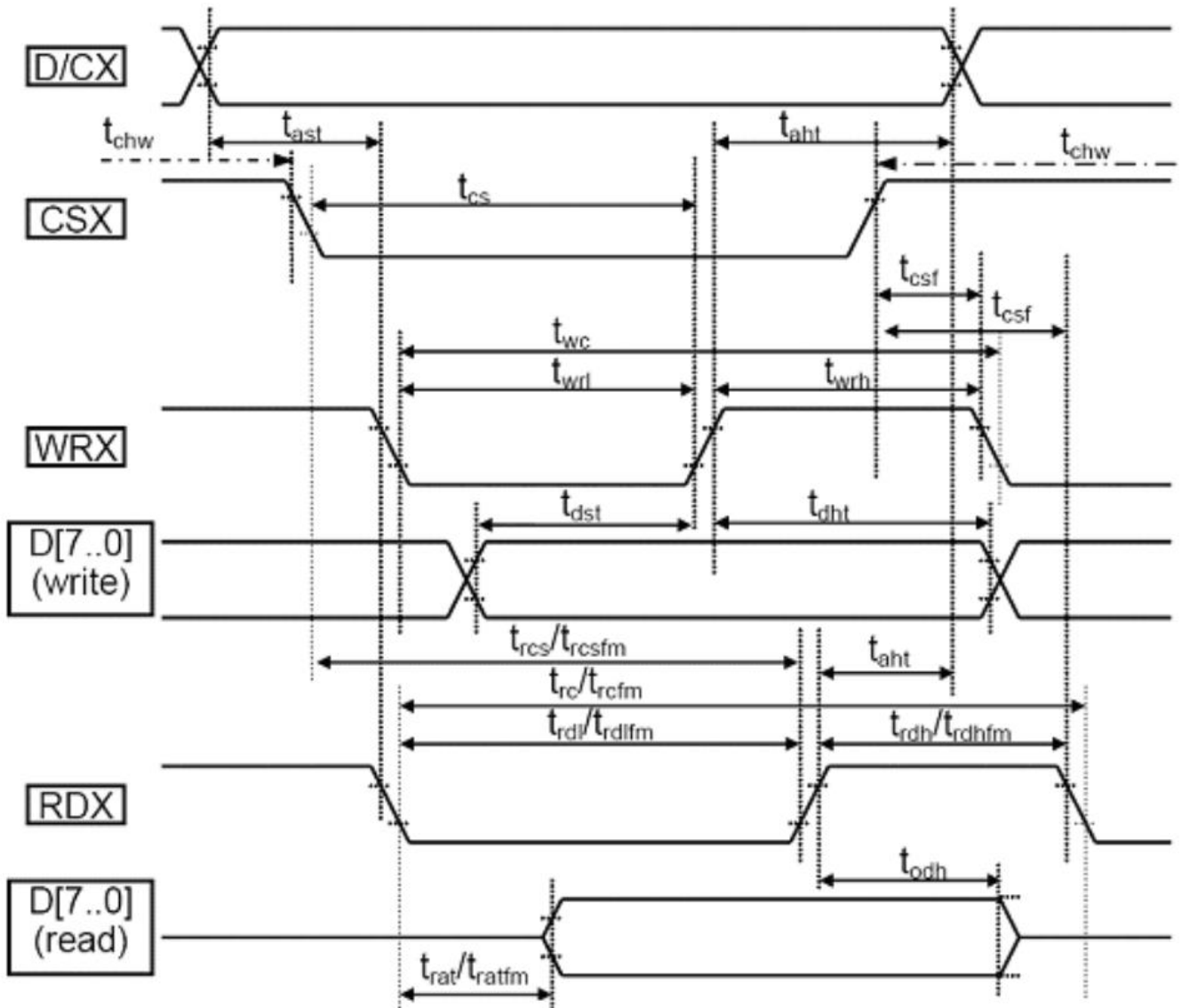

Note: Logic high and low levels are specified as 30% and 70% of VDDI for Input signals.

Signal	Symbol	Parameter	min	max	unit	description
D/CX	tast	Address setup time	0		ns	
	taht	Address hold time(Write/Read)	10		ns	
CSX	tchw	"S""H" Pulse Width	0		ns	
	tcs	Chip Select setup time (Write)	10		ns	
	trcs	Chip Select setup time (Read ID)	45		ns	
	trcsfm	Chip Select setup time (Read FM)	355		ns	
	tcsf	Chip Select Wait time(Write/read)	10		ns	
WRX	twc	Write cycle	66		ns	
	twrh	Control pulse H duration	15		ns	
	twrl	Control pulse L duration	15		ns	
RDX	trc	Read cycle (ID)	160		ns	When read ID data
	trdh	Control pulse H duration(ID)	90		ns	
	trdl	Control pulse L duration(ID)	45		ns	
RDX	trcfm	Read cycle (FM)	450		ns	When read from frame memory
	trdhfm	Control pulse H duration (FM)	90		ns	
	trdlfm	Control pulse L duration (FM)	355		ns	
D[17..0]	tdst	Data setup time	10		ns	For maximum CL = 30pF
	tdht	Data hold time	10		ns	
	trat	Read access time (ID)		40	ns	For minimum CL = 8pF
	tratfm	Read access time (FM)		340	ns	
	todh	Output disable time	20	80	ns	

Note 1: VDDI 1.65 to 3.3V, VDD=2.6 to 3.3V, AGND=GND=0V, Ta=-30 to 70 °C (to +85°C no damage)

Note 2: This input signal rise time and fall time (tr, tf) is specified at 15 ns or less. Logic high and low levels are specified as 30% and 70% of VDDI for input signals

Reset Timing

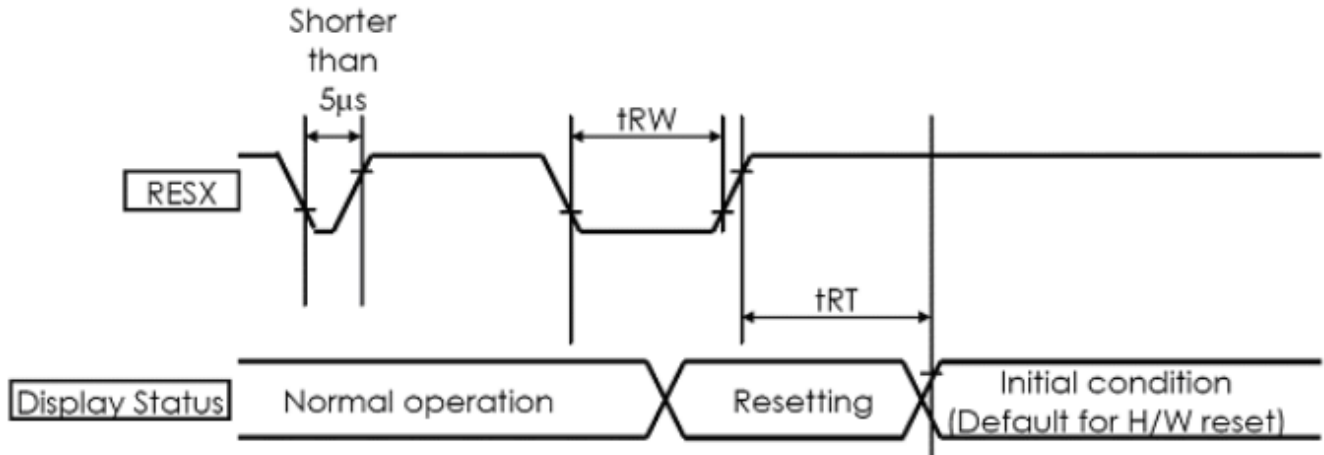

(VSS=0V, VDDI=1.65V to 1.95V, VCI=2.6V to 2.9V, Ta = -30 to 70°C)

Symbol	Parameter	Related Pins	MIN	TYP	MAX	Note	Unit
tRESW	*1) Reset low pulse width	RESX	10	-	-	-	µs
tREST	*2) Reset complete width	-	-	-	5	When reset applied during Sleep in mode	ms
		-	-	-	120	When reset applied during Sleep out mode	ms

Example Program Code

```

void TFT_18E_Init(void)
{
    GPIO_ResetBits(GPIOC, CS1);
    GPIO_SetBits(GPIOC, nRD);
    GPIO_ResetBits(GPIOC, nWR);
    GPIO_WriteBit(GPIOC, RES, Bit_RESET);
    delay(5);
    TFT_delay(10);
    GPIO_WriteBit(GPIOC, RES, Bit_SET);
    delay(100);
    TFT_delay(10);
    TFT_18E_Write_Command(0x11);
    TFT_delay(100);
    TFT_18E_Write_Command(0x26);TFT_18E_Write_Data(0x04);
    TFT_18E_Write_Command(0xF2);TFT_18E_Write_Data(0x00);
    TFT_18E_Write_Command(0xB1);TFT_18E_Write_Data(0x0A);TFT_18E_Write_Data(0x14);
    TFT_18E_Write_Command(0xC0);TFT_18E_Write_Data(0x0A);TFT_18E_Write_Data(0x00);
    TFT_18E_Write_Command(0xC1);TFT_18E_Write_Data(0x02);
    TFT_18E_Write_Command(0xC5);TFT_18E_Write_Data(0x2F);TFT_18E_Write_Data(0x3E);
    TFT_18E_Write_Command(0xC7);TFT_18E_Write_Data(0x40);
    TFT_18E_Write_Command(0x2A);
    TFT_18E_Write_Data(0x00);
    TFT_18E_Write_Data(0x00);
    TFT_18E_Write_Data(0x00);
    TFT_18E_Write_Data(0x7F);
    TFT_18E_Write_Command(0x2B);
    TFT_18E_Write_Data(0x00);
    TFT_18E_Write_Data(0x00);
    TFT_18E_Write_Data(0x00);
    TFT_18E_Write_Data(0x9F);
    TFT_18E_Write_Command(0x36);TFT_18E_Write_Data(0x48);
    TFT_18E_Write_Command(0x3A);TFT_18E_Write_Data(0xC5);
    TFT_18E_Write_Command(0x29);
    TFT_18E_Write_Command(0x2C);
}
/*****/
void TFT_18E_Write_Command(unsigned char command)
{
    GPIO_ResetBits(GPIOC, RS);
    GPIO_Write(GPIOB, command);
    GPIO_ResetBits(GPIOC, nWR);
    GPIO_SetBits(GPIOC, nWR);
}
/*****/
void TFT_18E_Write_Data(unsigned char data1)
{
    GPIO_SetBits(GPIOC, RS);
    GPIO_Write(GPIOB, data1);
    GPIO_ResetBits(GPIOC, nWR);
    GPIO_SetBits(GPIOC, nWR);
}
/*****/

```



Quality Information

Test Item	Content of Test	Test Condition	Note
High Temperature storage	Endurance test applying the high storage temperature for a long time.	+80°C, 96hrs	2
Low Temperature storage	Endurance test applying the low storage temperature for a long time.	-30°C, 96hrs	1,2
High Temperature Operation	Endurance test applying the electric stress (voltage & current) and the high thermal stress for a long time.	+70°C, 96hrs	2
Low Temperature Operation	Endurance test applying the electric stress (voltage & current) and the low thermal stress for a long time.	-20°C, 96hrs	1,2
High Temperature / Humidity Storage	Endurance test applying the electric stress (voltage & current) and the high thermal with high humidity stress for a long time.	+50°C, 90% RH, 96hrs	1,2
Thermal Shock resistance	Endurance test applying the electric stress (voltage & current) during a cycle of low and high thermal stress.	-20°C 60 min ~ +70°C 60 min, 20 cycles	
Vibration test	Endurance test applying vibration to simulate transportation and use.	10-50Hz, 1.5G amplitude. 30min in each of 3 directions X, Y, Z	3
Static electricity test	Endurance test applying electric static discharge.	Air: ±8kV 150pF/330Ω, 5 Times	
		Contact: ±4kV 150pF/330Ω, 5 Times	

Note 1: No condensation to be observed.

Note 2: Conducted after 4 hours of storage at 25°C, 0%RH.

Note 3: Test performed on product itself, not inside a container.