

LED Drivers for LCD Backlights

# White LED Driver for large LCD Panels (DCDC Converter Type)

## BD9420F

### General Description

BD9420F is high efficiency driver for white LED. This is designed for large sized LCD. BD9420F is built-in DCDC converter that supply appropriate voltage for light source.

BD9420F is also built-in protection function for abnormal state such as OVP: over voltage protection, OCP: over current limit protection of DCDC, SCP: short circuit protection, open detection of LED string. Thus this is used for conditions of large output voltage and load conditions.

### Features

- 6ch LED constant current driver(External PNP Tr Type)
- Maximum LED setting current 500mA(VREF Pin setting)
- $\pm 2\%$  LED current accuracy(VREF=0.9V setting)
- Built-in DC/DC converter
- Analog Dimming(Linear) function
- Built-in PWM-independent soft start circuit
- LED protection function(OPEN/SHORT protection)[PWM-independent Type]
- Individual detection and individual LED OFF for both OPEN and SHORT circuit
- VOUT Over Voltage Protection(OVP) and reduced voltage protection(SCP) circuit
- Built-in under voltage lockout function(UVLO) and over voltage protection(OVP)
- Built-in VOUT discharge circuit while shutdown

### Key Specifications

- VCC Supply Voltage Range: 9.0V to 35.0V
- DCDC Oscillation Frequency: 150kHz(RT=100k $\Omega$ )
- Operation Circuit Current: 5mA(Typ)
- Operating Temperature Range: -40°C to +85°C

### Applications

- LED driver for TV, Monitor and LCD Back Light

### Package

SOP28

W(Typ) x D(Typ) x H(Max)  
18.50mm x 9.90mm x 2.41mm  
Pin Pitch 1.27mm



Figure 1. SOP28

### Typical Application Circuit

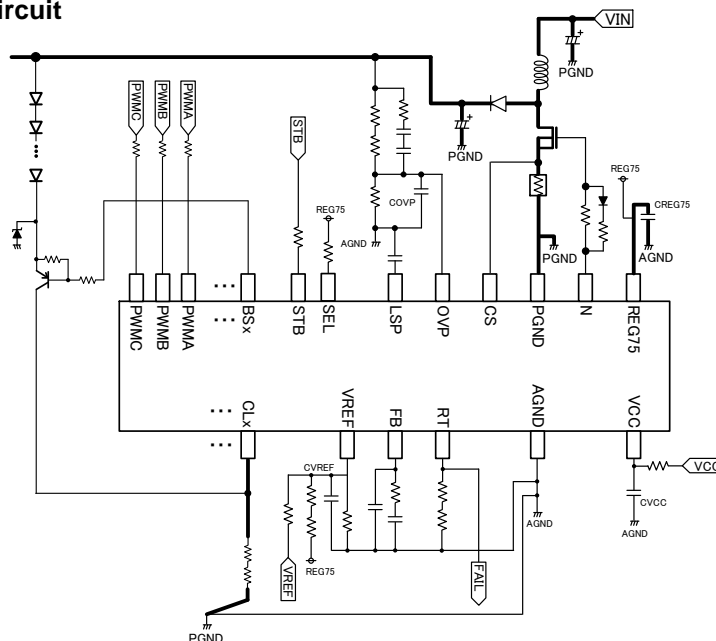

Figure 2. Typical Application Circuit

○Product structure : Silicon monolithic integrated circuit ○This product has no designed protection against radioactive rays

**Absolute Maximum Ratings(Ta = 25°C)**

Parameter	Symbol	Rating	Unit
Supply Voltage	VCC	-0.3 to +36	V
STB,OVP Voltage	STB,OVP	-0.3 to +36	V
BS1-6 Voltage	BS1-6	-0.3 to +60	V
CS,CL1-6,FB,RT,LSP Voltage	CS,CL1-6,FB,RT,LSP	-0.3 to +7	V
REG75,N Voltage	REG75,N	-0.3 to +14	V
PWMA-C,SEL,VREF Voltage	PWMA-C,SEL,VREF	-0.3 to +20	V
Power Dissipation for SOP28	Pd	0.75 (Note 1)	W
Operating Temperature Range	Topr	-40 to +85	°C
Storage Temperature Range	Tstg	-55 to +150	°C
Maximum Junction Temperature	Tjmax	150	°C

(Note 1) Derating is done 6.0 mW/°C for operating above Ta ≥ 25°C (Mount on 1-layer 70.0mm x 70.0mm x 1.6mm board)

**Caution:** Operating the IC over the absolute maximum ratings may damage the IC. The damage can either be a short circuit between pins or an open circuit between pins and the internal circuitry. Therefore, it is important to consider circuit protection measures, such as adding a fuse, in case the IC is operated over the absolute maximum ratings.

**Recommended Operating Conditions(Ta= -40°C to +85°C)**

Parameter	Symbol	Min	Typ	Max	Unit
Supply Voltage	VCC	9	24	35	V
DC/DC Oscillation Frequency	FSW	100	-	800	kHz
Analog Dimming Setting Input Range	VREF	0.6	0.9	3.0	V
LSP Setting Input Range	VLSP	0.3	-	2.5	V

**External Component Recommended Range**

Parameter	Symbol	Specification	unit
VCC pin connecting capacity	CVCC	1 to 100	uF
REG75 pin connecting capacity	C_REG	1.0 to 10	uF
RT pin connection resistance range	RRT	18.75 to 150	kΩ

The operating conditions listed above are constants for the IC alone. To make constant setting with practical set devices, utmost attention should be paid.

**Pin Configuration**

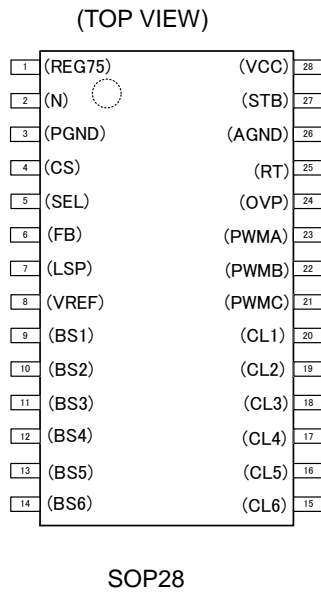

Figure 3. Pin Configuration

**Marking Diagram and Physical Dimension**

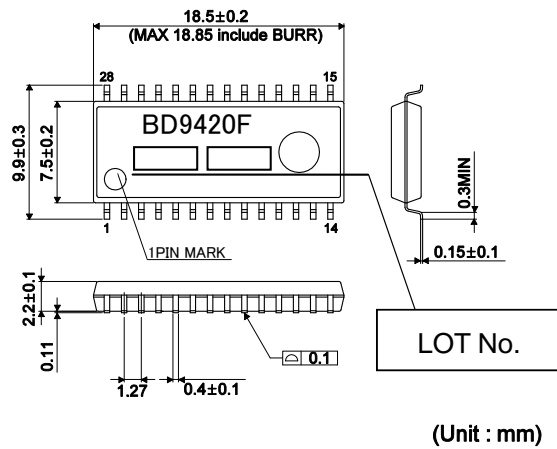

Figure 4. Physical Dimension

## Electrical Characteristics(Unless otherwise specified VCC=24V Ta=25°C)

Parameter	Symbol	Limit			Unit	Condition
		Min.	Typ.	Max.		
<b>[Whole Device]</b>						
Operation Current	ICC	—	5	10	mA	VSTB=3V
Standby Current	IST	—	40	80	uA	VSTB=0V
<b>[UVLO Block]</b>						
Operation Voltage (VCC)	VUVLO_VCC	6.5	7.5	8.5	V	VCC=SWEEP UP
Hysteresis Voltage (VCC)	VUHYS_VCC	150	300	600	mV	VCC=SWEEP DOWN
<b>[DC/DC Block]</b>						
Error amp Base Voltage	VEAMP	0.55	0.60	0.65	V	BSx pin, VREF=0.9V
Oscillation Frequency	FCT	142.5	150.0	157.5	kHz	RT=100kΩ
N Pin MAX DUTY Output	NMAX_DUTY	90	95	99	%	RT=100kΩ
N Pin Source ON Resistance	RNSO	2.5	5	10	Ω	
N Pin Sink ON Resistance	RNSI	2	4	8	Ω	
RT Pin Voltage	VRT	1.60	2.00	2.40	V	RT=100kΩ
RT Short Protection Range	RT_DET	-0.3	-	VRTx90%	V	RT=SWEEP DOWN
RT Pin Low Resistance	RRT_L	-	2.0	4.0	kΩ	VSTB=0V
FB Pin Source Current	IFBSO	-115	-100	-85	uA	VBSx=0V, VREF=0.9V, VFB=1.0V
FB Pin Sink Current	IFBSI	85	100	115	uA	VBSx=2.0V, VREF=0.9V, VFB=1.0V
Over Current Detect Voltage	VCS	0.35	0.40	0.45	V	CS=SWEEP UP
CS Source Current	ICS	15	30	60	uA	VCS=0V
<b>[DC/DC Protection Block]</b>						
OVP High Detect Voltage	VOVPH	2.88	3.00	3.12	V	VOVP SWEEP UP
OVP Hysteresis Voltage	VOVPH_HYS	150	200	250	V	VOVP SWEEP DOWN
Short Protection Detect Voltage	VSCP	0.05	0.10	0.15	V	VOVP SWEEP DOWN
OVP Pin Leakage Current	OVP_LK	-2	0	2	uA	VOVP=4V
<b>[LED PNP Driver Block]</b>						
CL Pin Current Setting Voltage	VCL	294.0	300.0	306.0	mV	VREF=0.9V
CL Pin Current Setting Voltage (Analog MAX)	VCLMAX	-3%	1.0	+3%	V	VREF max=3.0V
CL Pin Current Setting Voltage (Analog MIN)	VCLMIN	-3%	200.0	+3%	mV	VREF min=0.6V
PNP Driver Output Sink Resistance	RBS	55	80	120	Ω	PWM=High, VCL=Low
VREF Pin Leakage Current	VREF_LK	-2	0	2	uA	VREF=1V

## Electrical Characteristics(Unless otherwise specified VCC=24V Ta=25°C)

Parameter	Symbol	Limit			Unit	Condition
		Min.	Typ.	Max.		
<b>[LED Protection Block]</b>						
LED OPEN Detect Voltage	VOPEN	0.05	0.10	0.15	V	BSx=SWEEP DOWN
LED SHORT Detect Voltage	VLSP	8.5	9.0	9.5	V	BSx=SWEEP UP, LSP=OPEN
CL Pin Low Detect Voltage	VCLLVP	0.05	0.10	0.15	V	
LSP Pin Pull Up Resistance	RULSP	930	1550	2170	kΩ	LSP=0V
LSP Pin Pull Down Resistance	RDLSP	270	450	630	kΩ	LSP=4V
<b>[REG75 Block]</b>						
REG75 Output Voltage	REG75	7.425	7.50	7.575	V	Io=0mA
REG75 MAX Output Current	IREG75	10	—	-	mA	
REG75_UVLO Detect Voltage	REG75_TH	3.6	4.0	4.4	V	REG75=SWEEP DOWN
REG75_UVLO Hysteresis	REG75_HYS	250	500	750	mV	STB=ON->OFF, REG75=SWEEP UP
REG75 Discharge Resistance	REG75_DIS	0.65	1.00	1.35	MΩ	STB=ON->OFF, REG75=7.5V
<b>[STB Block]</b>						
STB Pin High Voltage	STBH	2.0	-	VCC	V	STB=SWEEP UP
STB Pin Low Voltage	STBL	-0.3	-	0.8	V	STB=SWEEP DOWN
STB Pin Pull Down Resistance	RSTB	600	1000	1400	kΩ	STB=3.0V
<b>[PWM Input Block]</b>						
PWM Pin High Detect Voltage	PWM_H	1.5	-	18	V	PWM=SWEEP UP
PWM Pin Low Detect Voltage	PWM_L	-0.3	-	0.8	V	PWM=SWEEP DOWN
PWM Pin Pull Down Resistance	RPWM	600	1000	1400	kΩ	PWM=3.0V
<b>[SEL Input Block]</b>						
SEL Pin High Detect Voltage	SEL_H	1.5	-	18	V	SEL=SWEEP UP
SEL Pin Low Detect Voltage	SEL_L	-0.3	-	0.8	V	SEL=SWEEP DOWN
SEL Pin Pull Down Resistance	RSEL	600	1000	1400	kΩ	SEL=3.0V

## Pin Descriptions

Pin No.	Pin Name	Function
1	REG75	7.5V regulator output for N output pin
2	N	DC/DC switching output pin
3	PGND	Power GND
4	CS	DCDC external NMOS current monitor pin
5	SEL	PWM select pin
6	FB	DCDC phase-compensation pin
7	LSP	LED short voltage setting pin
8	VREF	LED voltage setting pin
9	BS1	PNP Tr Base connecting pin1
10	BS2	PNP Tr Base connecting pin2
11	BS3	PNP Tr Base connecting pin3
12	BS4	PNP Tr Base connecting pin4
13	BS5	PNP Tr Base connecting pin5
14	BS6	PNP Tr Base connecting pin6
15	CL6	PNP Tr collector ·current detection pin6
16	CL5	PNP Tr collector ·current detection pin5
17	CL4	PNP Tr collector ·current detection pin4
18	CL3	PNP Tr collector ·current detection pin3
19	CL2	PNP Tr collector ·current detection pin2
20	CL1	PNP Tr collector ·current detection pin1
21	PWMC	Dimming signal input pin C
22	PWMB	Dimming signal input pin B
23	PWMA	Dimming signal input pin A
24	OVP	Overvoltage protection detection pin
25	RT	DCDC frequency setting resistor connection pin
26	AGND	Analog GND
27	STB	Enable pin
28	VCC	Power supply pin

Block Diagram

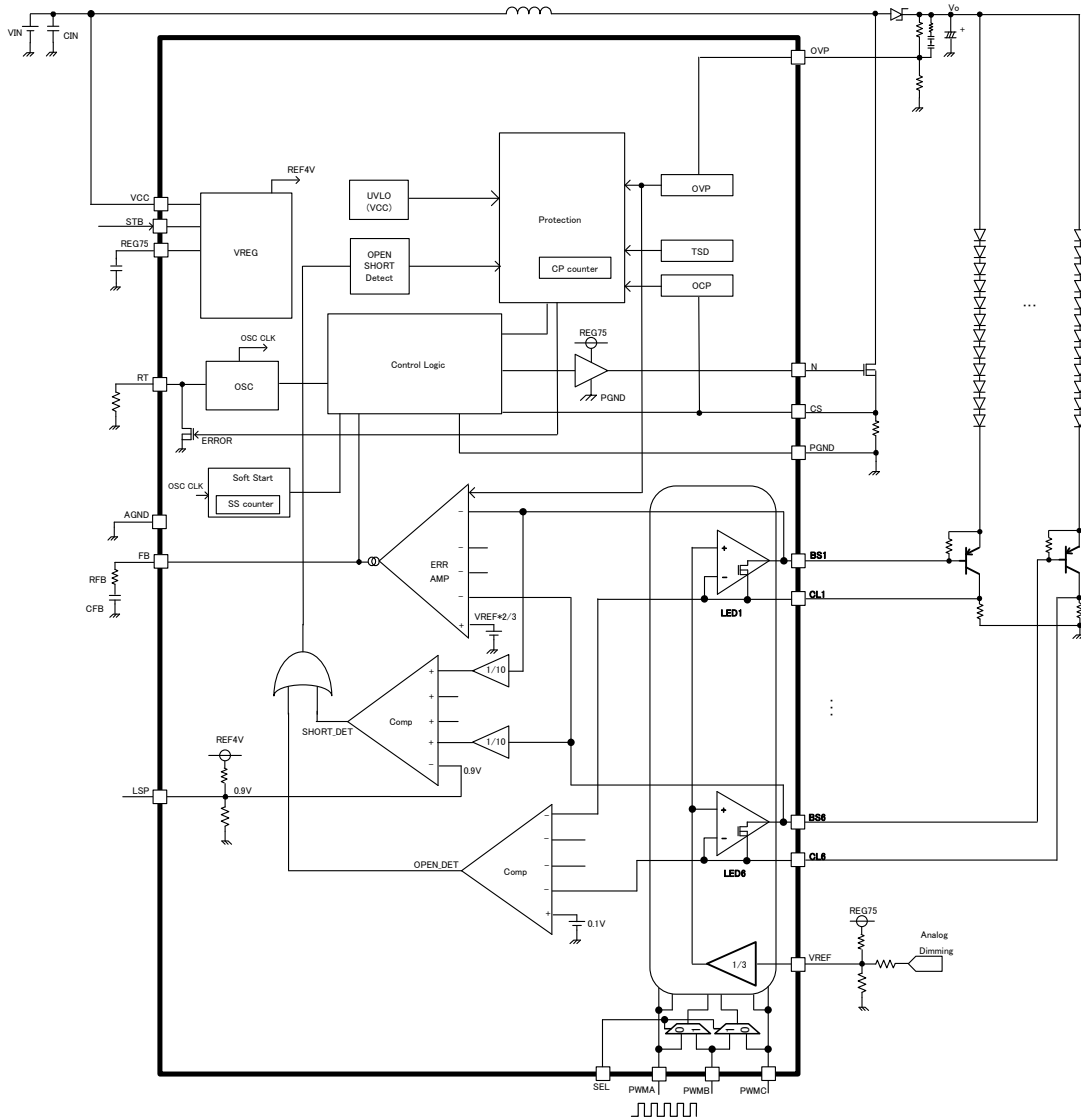

Figure 5. Blockdiagram

Pin ESD Type

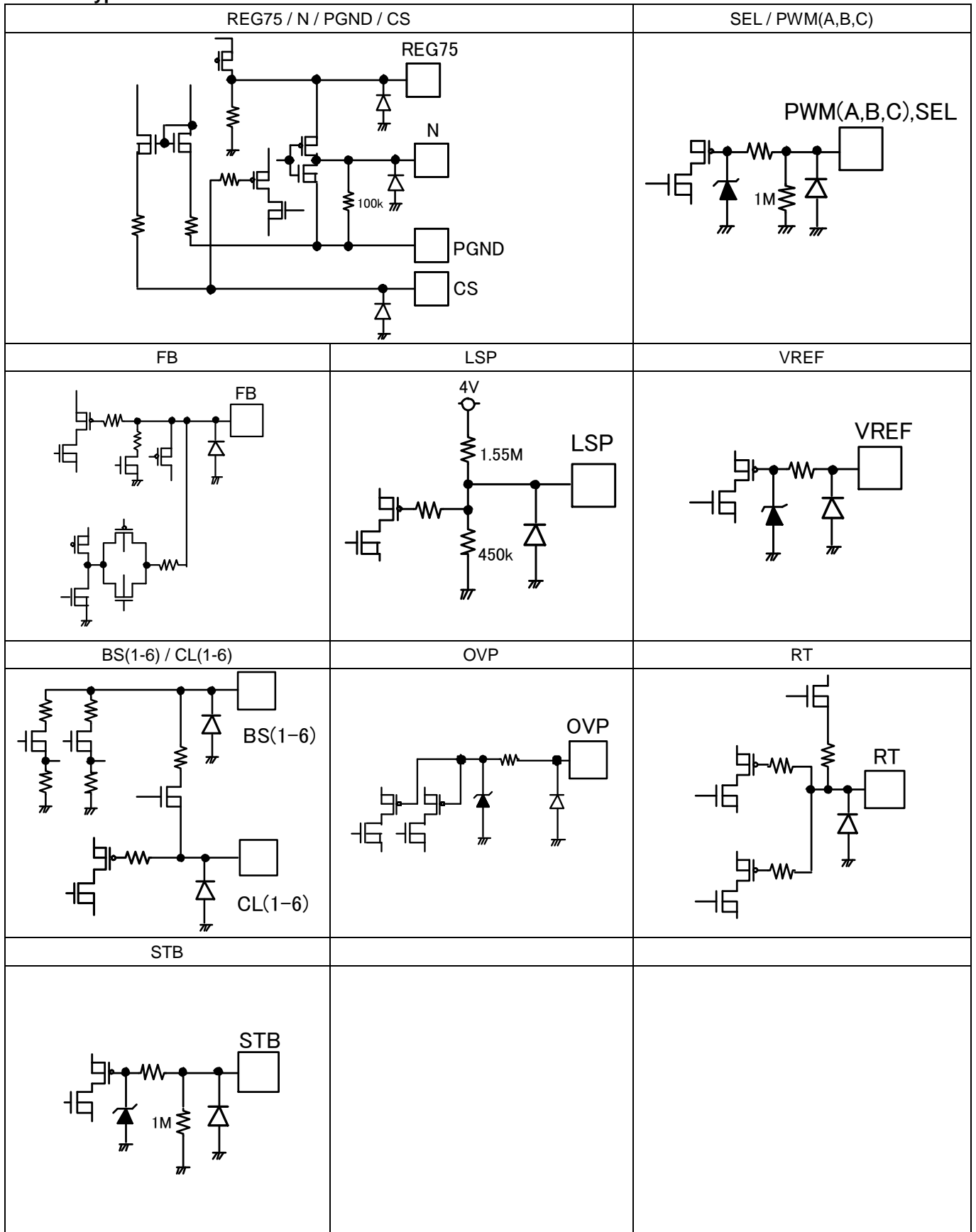

Figure 6. Pin ESD Type

## Description of pin function

### OP in 1: REG75

The REG pin is used in the DC/DC converter driver block to output 7.5V power. The maximum operating current is 10mA. Using the REG pin at a current higher than 10mA can affect the N pin output pulse, causing the IC to malfunction and leading to heat generation of the IC itself. To avoid this problem, it is recommended to make load setting to the minimum level.

### ○ Pin 2:N

The N pin is used to output power to the external NMOS gate driver for the DC/DC converter in the amplitude range of approx. 0 to 7.5V. Frequency setting can be made with a resistor connected to the RT pin. For details of frequency setting, refer to the description of the <RT pin>.

### ○ Pin 3: PGND

The PGND pin is a power ground pin for the driver block of the N output pin.

### ○ Pin 4: CS

CS pin is current detect for DC/DC current mode inductor current control pin.

Current flowing through the inductor is converted into voltage by the current sensing resistor RCS connected to the CS pin and this voltage is compared with voltage set with the error amplifier to control the DC/DC output voltage.

The CS pin also incorporates the overcurrent protection (OCP) function. If the CS pin voltage reaches 0.4V (Typ.) or more, switching operation will be forcibly stopped.

### ○ Pin 5: SEL

SEL pin is PWM control select pin. The PWM control mode is switched according to voltages input in the SEL pin. Avoid using the SEL pin between two states (0.8 to 1.5V).

SEL Voltage	State
SEL= 1.5V~18.0V	PWMA → CH1,CH2 common mode control PWMB → CH3,CH4 common mode control PWMC → CH5,CH6 common mode control
SEL= -0.3V~0.8V	PWMA → CH1,CH2,CH3 common mode control PWMB → no use PWMC → CH4,CH5,CH6 common mode control

### ○ Pin 6: FB

Current mode control DC/DC converter error amplifier output pin. By monitoring voltage of BS (1~6) pin, the highest Vf of LED column will set 2/3(typ.) of applied VREF voltage to BS pin voltage to control inductor current.

The phase compensation setting has described separately.

In addition, PWM pin will become High Impedance when all PWM signals are in low state, and will maintain FB voltage.

### ○ Pin 7: LSP

LED Short detect voltage setting pin. When LSP=OPEN, LSP pin voltage is 0.9V( typ), the BSx pin of LED SHORT detect voltage is set to 9V.

The 10 times of LSP pin voltage is the BSx pin LED SHORT protection detect voltage.

Please set LSP pin input voltage range from 0.3V~2.5V.

### ○ Pin 8: VREF

LED current setting pin. 1/3(typ) of applied voltage to VREF pin will be LED current feedback voltage, 2/3(typ.) of its voltage will be DCDC feedback voltage (the lowest BSx pin feedback voltage).

Basically, because high accuracy of resistor divider is inputted to VREF pin externally, the IC internally will be OPEN(High Impedance)state. Please use external power to design it. It cannot be used in OPEN state.

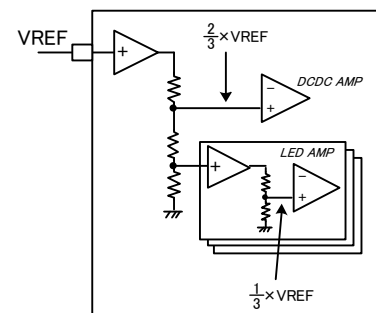

### ○ Pin 9-14: BS1-BS6

LED DRIVER output pin. Please connect to Base Terminal of external PNP Tr.

### ○ Pin 15-20: CL6 – CL1

LED current detect pin. By monitoring voltage of CLx pin to detect LED current.

Please connect resistor to collector pin of external PNP Tr. CLx pin of no use channel set CLx>3.3V.



○ **Pin 21-23: PWMC, PWMB, PWMA**

ON/OFF terminal of LED driver pin. It inputs PWM dimming signal directly to adjust output DUTY dimming.  
For details of PWM control state, refer to the description of the <SEL pin>.  
High/Low level of PWM terminal is shown as follows:

State	PWM Voltage
LED ON state	PWM= 1.5V~18.0V
LED OFF state	PWM= -0.3V~0.8V

○ **Pin 24: OVP**

The OVP pin is an input pin for overvoltage protection and short circuit protection of DC/DC output voltage. When voltage of it over 3.0V or higher, CP counting start.

When OVP pin voltage<0.1V (typ.) or lower, short circuit protection (SCP) function is activated, and output of Gate driver will become low immediately.

○ **Pin 25: RT**

RT sets charge/discharge current determining frequency inside IC.

Only a resistor connected to RT determines saw-tooth wave frequency inside IC.

When RT=100kΩ, Frequency=150kHz(typ.).

For calculation example, please refer to section in "P15 – DC/DC drive frequency setting".

When it reaches under  $\sqrt{RT} \times 0.90V$ (typ), DCDC operation will be stopped in order to prevent from high speed oscillation when the RT resistance is shorted to GND. And when RT pin returns to normal state, DCDC also returns to operation.

○ **Pin 26: AGND**

GND pin for analog system inside IC.

○ **Pin 27: STB**

ON/OFF setting pin and allowed for use to reset the IC from shutdown.

※The IC state is switched (i.e., The IC is switched between ON and OFF state) according to voltages input in the STB pin. Avoid using the STB pin between two states (0.8 to 2.0V).

○ **Pin 28: VCC**

Power source pin of IC, which should be input in the range of 9 – 35 V.

Operation starts when VCC is 7.5V (TYP.) or higher and shuts down when VCC is 7.2 V (TYP.).

Typical Performance Curves

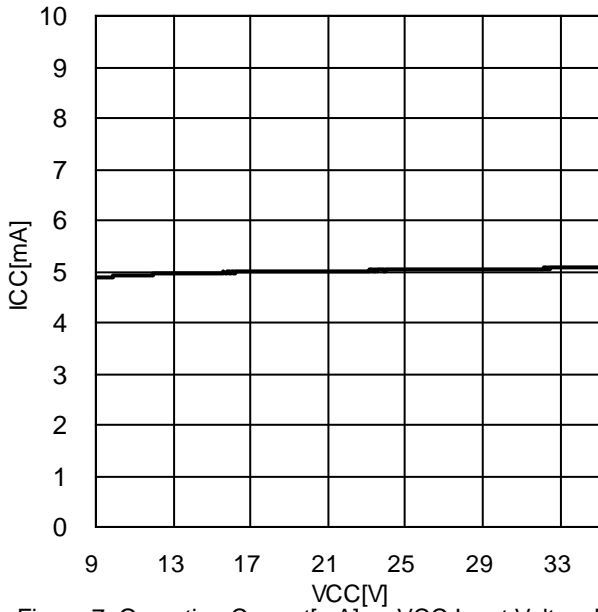

Figure 7. Operating Current[mA] vs VCC Input Voltage[V]

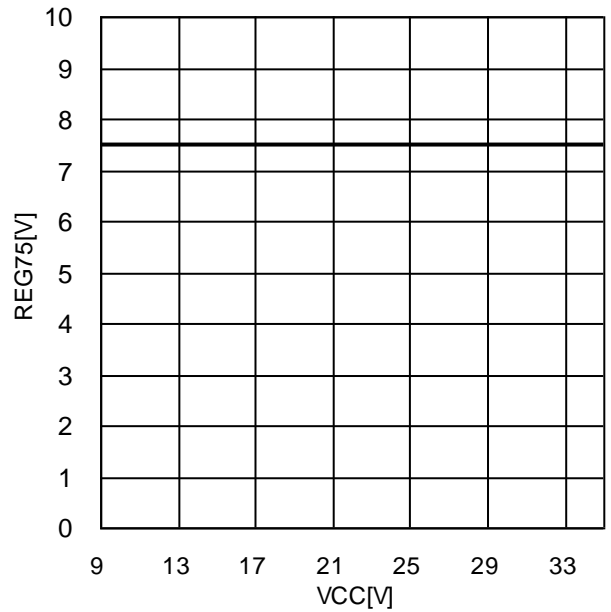

Figure 8. REG75 Output Voltage[V] vs VCC Input Voltage[V]

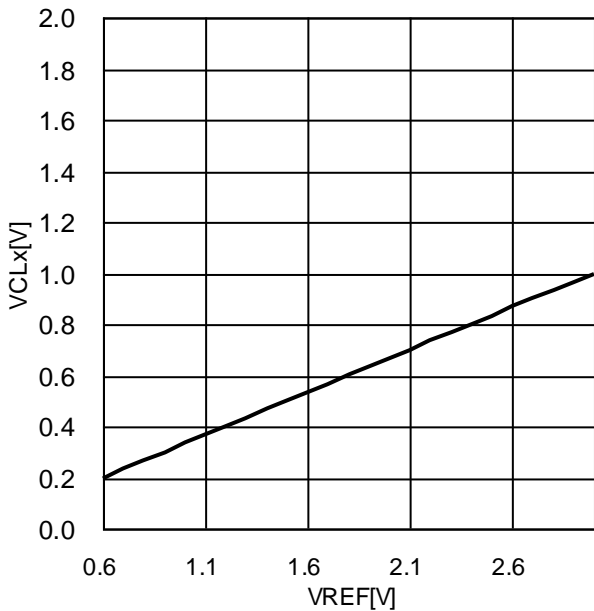

Figure 9. CLx Voltage[V] vs VREF Input Voltage[V]

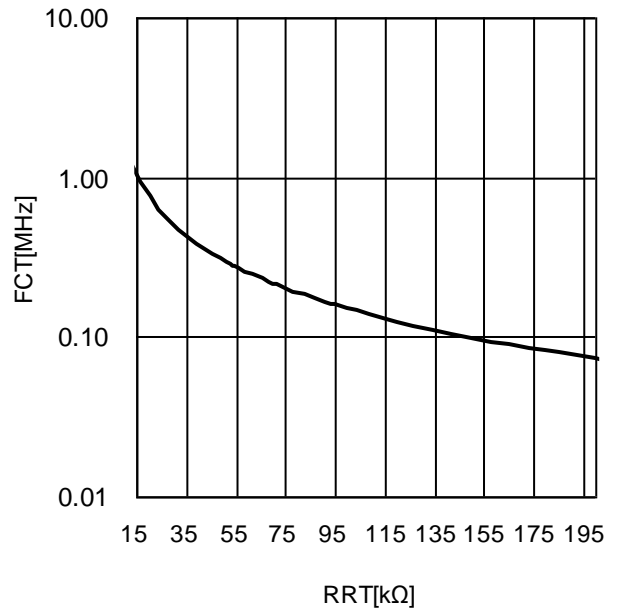

Figure 10. N Frequency[MHz] vs RT Resistance[kΩ]

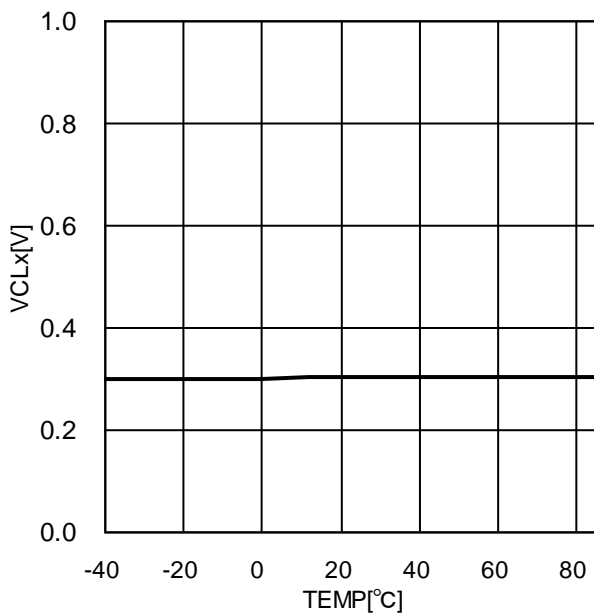

Figure 11. CLx Voltage[V] vs Temperature[°C]

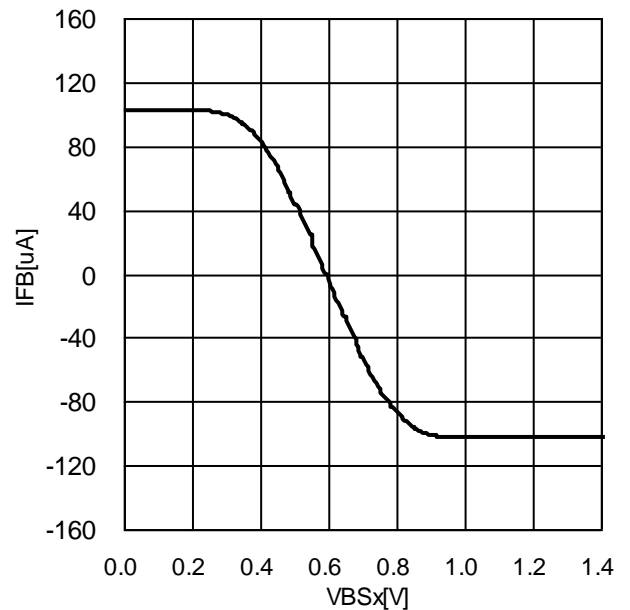

Figure 12. FB Current[μA] vs BSx Voltage[V]

●LED current setting (VREF pin, CLx pin)

Please decide VREF pin input voltage first. When Analog dimming is performed, please be noted that VREF pin input voltage range is (0.6V ~ 3.0V), and decide the input voltage in normal operation. Basically, if VREF pin voltage is high, it will cause power dissipation of external PNP Tr become high, so it is preferred to set the VREF pin voltage lower.

Later, VREF=0.9V will be set as basic. For example if you create 0.9V from REG75, it is possible to use resistive divider by setting 88kohm and 12kohm.

The LED current detection is performed by CLx pin. CLx pin is controlled so that the voltage of 1/3V(typ.) of VREF voltage. If VREF=0.9V, CLx=0.3V to control external PNP Tr. Therefore, if 「R<sub>CL</sub>」 is set as a resistance which between CLx pin and GND, and VREF pin voltage is set as 「V<sub>VREF</sub>」, LED current 「I<sub>LED</sub>」can be calculated as below.

$$R_{CL} [ohm] = \frac{V_{VREF} [V]}{I_{LED} [A] \times 3}$$

For current setting, set at each channel. For this reason, in 1ch~3ch and 4ch~6ch, it is possible to change current by setting 「R<sub>CL</sub>」value.

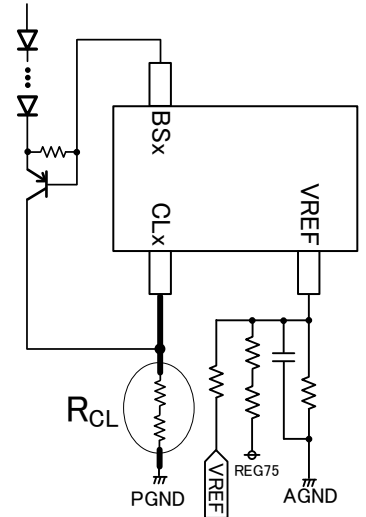

●DCDC operation frequency setting (RT Pin)

The operation frequency of DCDC output is set by resistance which connected to RT pin.

○The relationship between operation and RT resistance (ideal)

$$R_{RT} = \frac{15000}{f_{sw} [kHz]} [k\Omega]$$

Here, f<sub>sw</sub>=DCDC converter oscillation frequency[kHz]

Above is an ideal equation which do not putted with correction terms. For accurate frequency setting, please confirm on the real system. But the frequency setting range is 100kHz~800kHz.

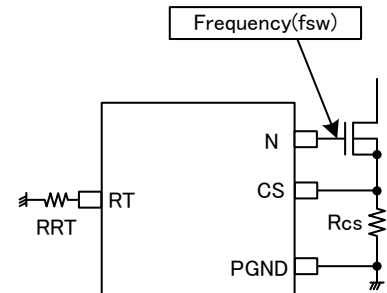
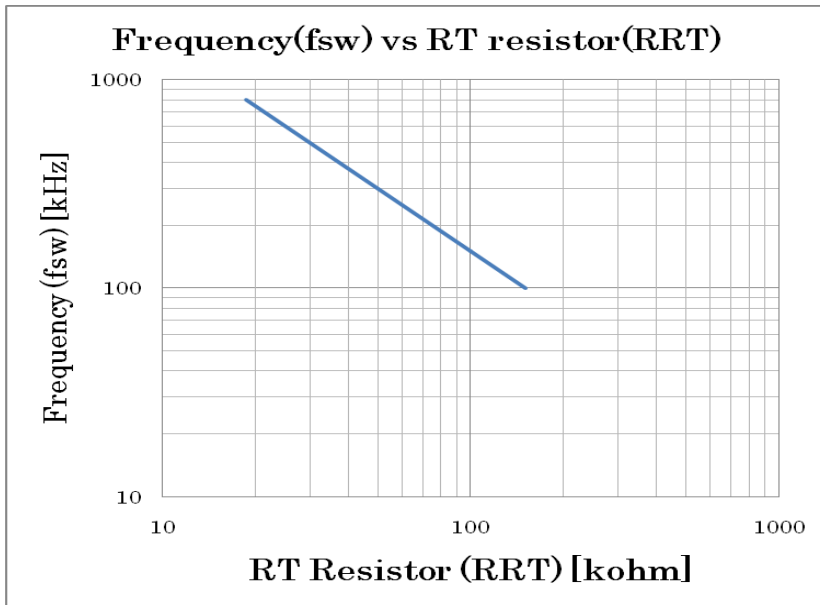

【Setting Example】

If DCDC frequency is set to be 200kHz, RRT as below:

$$R_{RT} = \frac{15000}{f_{sw} [kHz]} = \frac{15000}{200[kHz]} = 75 [k\Omega]$$

### ●Maximum DCDC output Voltage

In this IC, the voltage of BSx pin is depending on VREF pin voltage. The maximum voltage of VREF pin (VREF=3.0V), the voltage of BSx pin will become 2.0V (2/3 of VREF voltage).

The maximum voltage of DCDC output will have be vary with 1.6V while Analog dimming is performed (2/3 of 3.0V - 0.6V).

### ●Soft Start Time setting

This IC have a built in soft start time setting, there is no need to change from the outside. Timer time can be set by counting the clock frequency with RT pin. Starts counting when shutdown function terminal STB etc is released, and start time are considered in the count (in soft-start). Therefore, LED OPEN protection ·SHORT protection are not detected during this time.

The soft start time is set inside the IC, as the following equation.

(Please note that soft-start time set here is the mask of the running time and not the time until the output stabilizes of the DCDC. Time to stabilize the output or load is greater than the boost DCDC dependent.)

Soft-start time "TSS", RT pin connection resistor "RRT" :

$$T_{SS}[\text{sec}] = 12480 \times \frac{R_{RT}[\Omega]}{1.5 \times 10^{10}}$$

### Start-up sequence

The following describes the start-up sequence of this IC.

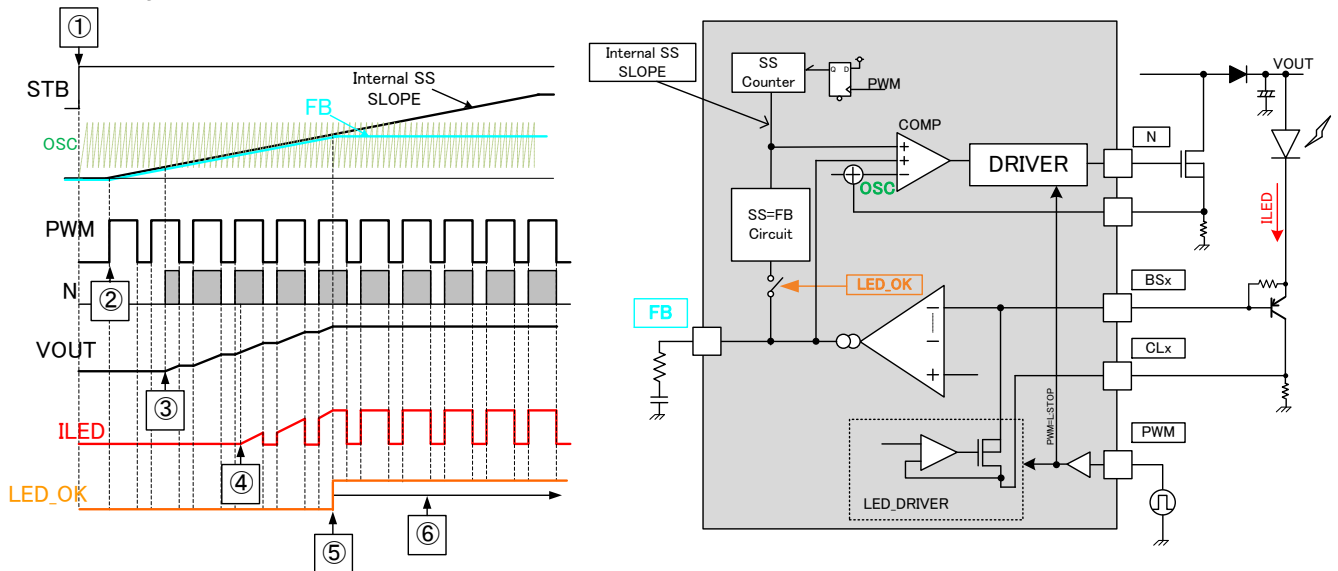

### ○Description of start-up sequence

①Set STB from Low to High

②System will be activated while PWM=H. SS counting start.

At this time, a circuit in which internal SS voltage for slow start becomes equal to FB pin voltage operates to equalize the FB pin and internal SS voltages regardless of whether the PWM pin is set to Low or High level.

③Since the FB pin and internal SS reach the lower limit of the internal sawtooth wave of the IC, the DC/DC converter operates to start VOUT voltage rising.

④The Vout voltage continues rising to reach a voltage at which LED current starts flowing.

⑤When the LED current reaches the amount of current, isolate the FB circuit from the SS circuit. With this, the startup operation is completed.

⑥After that, normal operation is controlled by following the feedback voltage of LED pins.

If the SS pin voltage reaches 4V or higher, the LED protection function will be activated to forcedly end the SS and FB equalizing circuit.

● **OVP/SCP setting procedure (OVP Pin)**

The OVP pin is an input pin for overvoltage protection and short circuit protection of DC/DC output voltage. The OVP pin is a high impedance type and no pull-down resistor inside, resulting in unstable potential in the open circuit state. To avoid this problem, be sure to make input voltage setting with the use of a resistive divider.

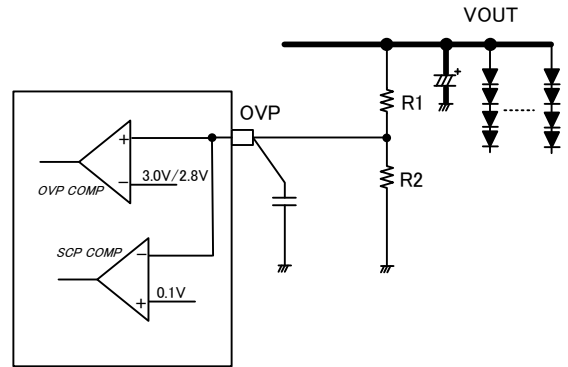

○ **OVP detect setting equation**

Assuming that voltage of VOUT rising abnormally and detecting OVP is “VOVP<sub>DET</sub>”, R1 and R2 setting will be made by the following equation.

$$R1 = R2[k\Omega] \times \frac{(VOVP_{DET}[V] - 3.0[V])}{3.0[V]} \quad [k\Omega]$$

○ **OVP release setting equation**

When R1 and R2 setting is determined by the equation shown above, OVP release voltage VOVP<sub>CAN</sub> will be give by the following equation :

$$VOVP_{CAN} = 2.8V \times \frac{(R1[k\Omega] + R2[k\Omega])}{R2[k\Omega]} \quad [V]$$

○ **SCP detect setting**

The SCP setting「VSCP<sub>DET</sub>」 voltage is calculated as below when R1,R2 is decided above:

$$VSCP_{DET} = 0.1V \times \frac{(R1[k\Omega] + R2[k\Omega])}{R2[k\Omega]} \quad [V]$$

### ●LED short voltage setting(BSx pin, LSP pin)

The detection voltage of LED short when BSx pin higher than 9V while LSP pin is in OPEN state.

It is possible to change the LED short detection voltage, please input (0.3V~2.5V) to LSP pin.

The relationship between LED short detection voltage 「 $V_{LED_{short}}$ 」, and LSP pin voltage 「 $V_{LSP}$ 」 as below equation.

$$V_{LSP} [V] = \frac{V_{LED_{short}} [V]}{10}$$

In addition, because LSP pin has split 4V of terminal resistance inside IC.

(Refer to upper right schematic), it will be combined resistance value of IC's internal resistance and connecting to external resistor. For this reason, when configure the voltage of LSP in resistor divider, it is recommended to connect a resistor which has a little impact from internal resistance value. (Resistance is less susceptible to internal resistor, but care must be taken because power consumption will become large.)

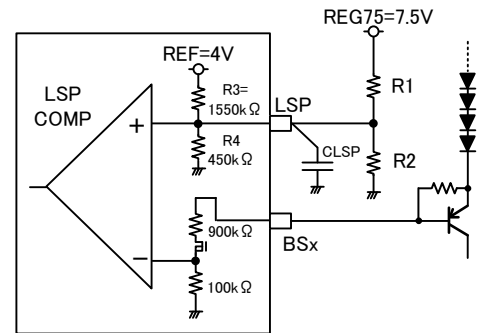

### ○LSP setting procedure

Below equation shows how to calculate the detection voltage of VLSP by using R1,R2 resistor divide which connect to REG50 voltage.

$$VLSP = \left( REG75[V] \times \frac{R2[k\Omega]}{R1[k\Omega] + R2[k\Omega]} \right) \times 10 [V] \dots (1)$$

However, this equation is without considering IC resistance. If internal resistance is taken into account, the detection voltage VLSP will be given by the following equation:

$$VLSP = \left( \frac{R2[k\Omega] \times R4[k\Omega] \times (REG50[V] \times R3 + REF[V] \times R1[k\Omega])}{(R1[k\Omega] \times R3[k\Omega] \times (R2 + R4) + R2[k\Omega] \times R4[k\Omega] \times (R1[k\Omega] + R3[k\Omega]))} \right) \times 10 [V] \dots (2)$$

Please set R1 and R2 resistance so that a difference between resistance values found by Equations (1) and (2) will come to approximately 2% or less as a reference.

### 【Setting example】

Assuming that LSP is approximated by Equation (1) in order to set LSP detection voltage to 5V, R1 comes to 51kΩ and R2 comes to 3.6kΩ.

When calculating LSP detection voltage taking into account internal IC resistance by Equation (2), it will be given as:

$$VLSP = \left( \frac{3.6[k\Omega] \times 450[k\Omega] \times (7.5[V] \times 1550[k\Omega] + 4[V] \times 51[k\Omega])}{(51[k\Omega] \times 1550[k\Omega] \times (3.6[k\Omega] + 450[k\Omega]) + 3.6[k\Omega] \times 450[k\Omega] \times (51[k\Omega] + 1550[k\Omega]))} \right) \times 10 = 4.984[V]$$

The difference is given as:

$$(4.984[V] - 5[V]) / 5[V] \times 100 = -0.32\%$$

As a result, this setting will be little affected by internal impedance.

※**For the selection of DC/DC components, please also consider the inaccuracy of each components.**

●Timer latch function

This IC has a built-in timer latch counter to make setting of timer latch time by counting a clock frequency set with the RT pin.

○Timer latch time

The timer latch counter begins counting from the timing when any abnormal state is detected. The timer will be latched after a lapse of a period of time given by the following equation.

If the abnormal state continues even when PWM is set to Low level, the counter will not reset counting.

$$LATCH_{TIME} = 2^{15} \times \frac{R_{RT}}{1.5 \times 10^{10}} = 32768 \times \frac{R_{RT} [k\Omega]}{1.5 \times 10^7} [S]$$

Here LATCH<sub>TIME</sub>= A period of time, which the timer is latched  
 R<sub>RT</sub>=RT pin connecting resistance

Protection time which described above is applied for LED OPEN protection, LED SHORT protection, SCP protection, OVP protection as below:

$$LATCH_{TIME} = 2^{18} \times \frac{R_{RT}}{1.5 \times 10^{10}} = 262144 \times \frac{R_{RT} [k\Omega]}{1.5 \times 10^7} [S]$$

Clock oscillation of timer latch uses DCDC clock. So timer latch time depend on unevenness of DCDC oscillation. In 150kHz, timer latch time is ±5% unevenness.

【Setting Example】

In LED\_OPEN protection, LED\_SHORT protection, SCP protection, When RT resistance=100kohm, the timer latch time is

$$LATCH_{TIME} = 2^{15} \times \frac{R_{RT}}{1.5 \times 10^{10}} = 32768 \times \frac{100[k\Omega]}{1.5 \times 10^7} = 0.218 [S]$$

And OVP protection is

$$LATCH_{TIME} = 2^{18} \times \frac{R_{RT}}{1.5 \times 10^{10}} = 262144 \times \frac{100[k\Omega]}{1.5 \times 10^7} = 1.75 [S]$$

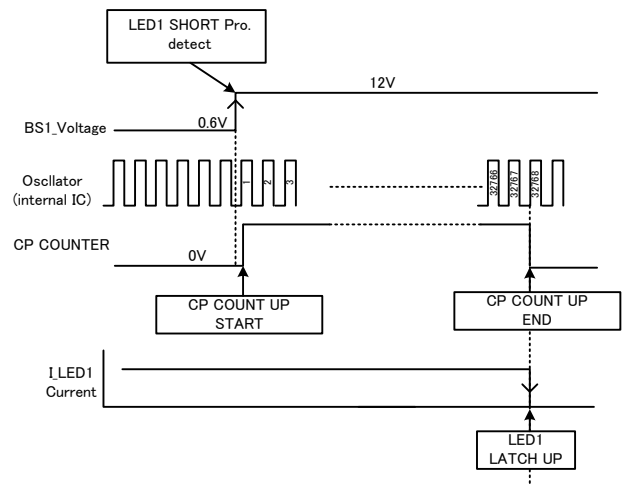

Figure 13-1. Timing chart of LSP time latch

To prevent the miss detection there is 4 count interval of mask before starting the timer count at LED OPEN, SHORT and GND SHORT protection.

If PWM=H time is

PWM=H time < 4count . . . Not detect protection because it is in interval time

PWM=H time > 4count . . . Detect protection because it is out of interval time

Please verify enough to operate narrow PWM.

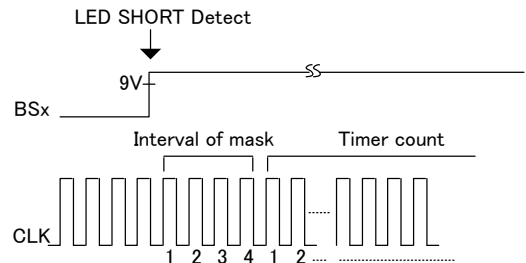

Figure 13-2. Timing chart of Timer count

● Selection of DC/DC Components

**OCP setting / DCDC component current tolerance selection guide**

The OCP detection function that is one of the functions of the CS pin will stop the DC/DC converter operating if the CS pin voltage becomes larger than 0.4V. Consequently, it is needed to calculate a peak current flowing through the coil L and then review the resistance of RCS. Furthermore, a current tolerance for DC/DC components should be larger than that for peak current flowing through the coil L. The following describes the peak coil current calculation procedure, CS pin connection resistor RCS selection procedure, and DC/DC component current tolerance selection procedure.

○ Peak coil current I<sub>peak</sub> calculation

Ripple voltage generated at the CS pin is determined by conditions for DC/DC application components first, Assuming the conditions as below:

- 「output voltage=V<sub>OUT</sub>[V]」
- 「LED total current=I<sub>OUT</sub>[A]」
- 「DCDC input voltage=V<sub>IN</sub>[V]」
- 「DCDC efficiency=η[%]」

And then mean input current I<sub>IN</sub> required for the whole system is given by the following equation.

$$I_{IN} = \frac{V_{OUT}[V] \times I_{OUT}[A]}{V_{IN}[V] \times \eta[\%]} \quad [A]$$

Further, according to drive operation with the DC/DC converter switching frequency f<sub>sw</sub> [Hz], inductor ripple current ΔIL [A] generated at the inductor L (or H) is given by the following equation.

$$\Delta IL = \frac{(V_{OUT}[V] - V_{IN}[V]) \times V_{IN}[V]}{L[H] \times V_{OUT}[V] \times f_{sw}[Hz]} \quad [A]$$

As a result, the peak current I<sub>peak</sub> of IL is given by the following equation.

$$I_{peak} = I_{IN}[A] + \frac{\Delta IL[A]}{2} \quad [A] \dots (1)$$

○ CS pin connection resistor RCS selection procedure

The current I<sub>peak</sub> flows into RCS to generate voltage. (See the timing chart shown to the right) The voltage V<sub>CSpeak</sub> is given by the following equation.

$$V_{CS\ peak} = R_{cs} \times I_{peak} \quad [V]$$

If V<sub>CSpeak</sub> voltage reaches 0.4V, DC/DC output will stop. Consequently, to select RCS resistance, the following condition should be met.

$$R_{cs} \times I_{peak}[V] < 0.4[V]$$

○ DC/DC component current tolerance selection procedure

I<sub>ocp</sub> current needed for OCP detection voltage CS to reach 0.4V is given by the following equation:

$$I_{ocp} = \frac{0.4[V]}{R_{cs}[\Omega]} \quad [A] \dots (2)$$

The relation among I<sub>peak</sub> current (Equation (1)), I<sub>ocp</sub> current (Equation (2)), and Maximum current tolerance for component should meet the following equation.

$$I_{peak} < I_{ocp} < \text{MAX current tolerance}$$

DC/DC application components including FETs, inductors, and diodes should be selected so that the Equation shown above will be met.

In addition, it is recommended to use continuous mode in DCDC application. And the lower limit value of coil ripples current I<sub>min</sub> so as to meet the following equation:

$$I_{min} = I_{IN}[A] - \frac{\Delta IL[A]}{2} [A] > 0$$

A failure to meet this condition is referred to as discontinuous mode and this failure may result in an inadequate rise in output voltage.

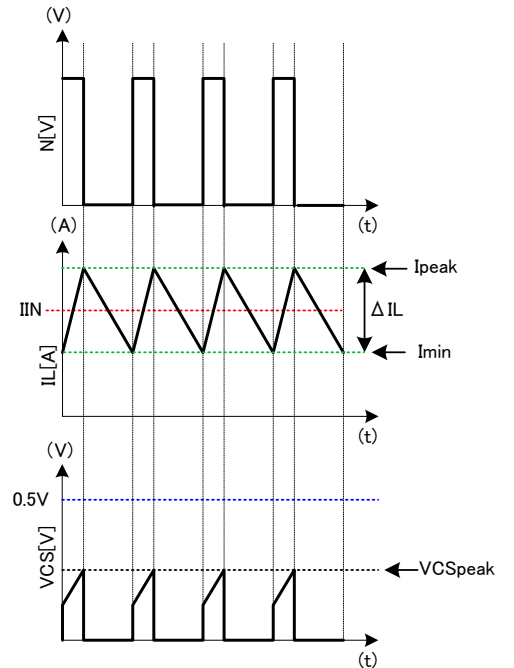
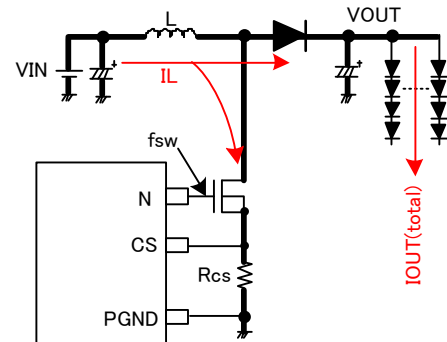



**【Setting example】**

Output=VOUT[V]=40V

LED 1ch current=120mA, total LED current IOUT[A]=120mA×6ch=0.72A

DCDC input voltage=VIN [V] =24V

DCDC efficiency=η[%]=90%

Mean input current IIN required for the whole system is given by the following equation:

$$I_{IN} [A] = \frac{V_{OUT} [V] \times I_{OUT} [A]}{V_{IN} [V] \times \eta [\%]} = \frac{40[V] \times 0.72[A]}{24[V] \times 0.9} = 1.33 [A]$$

DCDC switching frequency=fsw[Hz]=200kHz

Inductor [H]=33μH

The inductor ripple current ΔIL [A] is given by the following equation:

$$\Delta IL = \frac{(V_{OUT} [V] - V_{IN} [V]) \times V_{IN} [V]}{L [H] \times V_{OUT} [V] \times f_{sw} [Hz]} = \frac{(40[V] - 24[V]) \times 24[V]}{33 \times 10^{-6} [H] \times 40[V] \times 200 \times 10^3 [Hz]} = 1.45 [A]$$

As a result, the peak current Ipeak of IL is given by the following equation.

$$I_{peak} = I_{IN} [A] + \frac{\Delta IL [A]}{2} [A] = 1.33[A] + \frac{1.45[A]}{2} = 2.06[A]$$

When RCS resistance is set to 0.1ohm, the VCS peak voltage will be given by the following equation:

$$VCS_{peak} = Rcs \times I_{peak} = 0.1[\Omega] \times 2.06[A] = 0.206[V] < 0.4 [V]$$

Consequently, the result meets the condition.

Furthermore, Iocp current at which OCP is detected is given by the following equation:

$$I_{OCP} = \frac{0.4[V]}{0.1[\Omega]} = 4.0 [A]$$

So must select the component of about 5A in order to meet the above result.

$$I_{peak} < I_{OCP} < \text{Max. Current tolerance for component} = 2.06[A] < 4.0 [A] < 5.0 [A]$$

**Particularly, To select DC/DC components, give consideration to IC variations as well as individual component variations, and then conduct thorough verification on practical systems.**

The lower limit value of coil ripple current Imin is given by the following equation, the component will not be put into discontinuous mode.

$$I_{min} = I_{IN} [A] - \frac{\Delta IL [A]}{2} [A] = 1.33[A] - 0.73[A] = 0.60[A] > 0$$

※**For the selection of DC/DC components, please also consider the inaccuracy of each components.**

○ Selection of inductor L

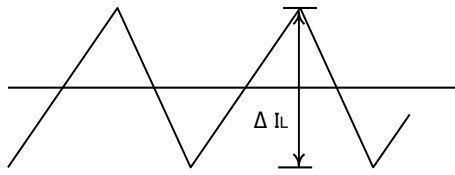

The value of inductor has significant influence on the input ripple current. As shown by Equation (1), the larger the inductor and the higher the switching frequency, the inductor ripple current  $\Delta I_L$  becomes increasingly lower.

$$\Delta I_L = \frac{(V_{OUT} - V_{IN}) \times V_{IN}}{L \times V_{OUT} \times f_{SW}} [A] \quad \dots \dots (1)$$

Expressing efficiency as shown by Equation (2), peak input current is given as Equation (3).

$$\eta = \frac{V_{OUT} \times I_{OUT}}{V_{IN} \times I_{IN}} \quad \dots \dots (2)$$

$$I_{LMAX} = I_{IN} + \frac{\Delta I_L}{2} = \frac{V_{OUT} \times I_{OUT}}{V_{IN} \times \eta} + \frac{\Delta I_L}{2} \quad \dots \dots (3)$$

Here,

- L: Inductor value[H]       $V_{OUT}$ : DC/DC output voltage[V]
- $V_{IN}$ : input voltage[V]       $I_{OUT}$ : output total current[A]
- $I_{IN}$ : input current[A]       $f_{SW}$ : Oscillation frequency[Hz]

Basically, make setting of  $\Delta I_L$  to approximately 30% to 50% of the output load current.

※ If a current in excess of the rated current of the inductor applies to the coil, the inductor will cause magnetic saturation, resulting in efficiency degradation.

Select an inductor with an adequate margin so that peak current will not exceed the rated current of the inductor.

※ To reduce power dissipation from and increase efficiency of inductor, select an inductor with low resistance component (DCR or ACR).

○ Selection of output capacitor  $C_{OUT}$

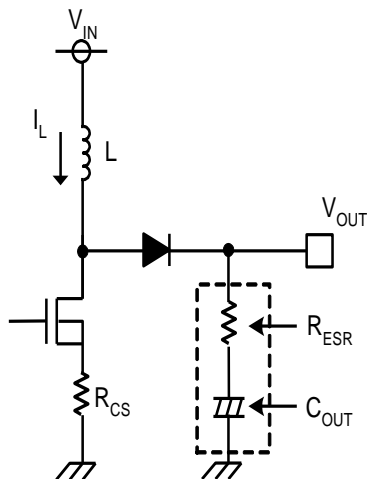

Select a capacitor on the output side taking into account the stability region of output voltage and equivalent series resistance necessary to smooth ripple voltage. Note that higher output ripple voltage may result in a drop in LED pin voltage, making it impossible to supply set LED current. The output ripple voltage  $\Delta V_{OUT}$  is given by Equation (4).

$$\Delta V_{OUT} = I_{LMAX} \times R_{ESR} + \frac{1}{C_{OUT}} \times \frac{I_{OUT}}{\eta} \times \frac{1}{f_{SW}} [V] \quad \dots \dots (4)$$

Here,  $R_{ESR}$  = Equivalent series resistance of  $C_{OUT}$ .

※ Select capacitor ratings with an adequate margin for output voltage.

※ To use an electrolytic capacitor, an adequate margin should be provided for permissible current. Particularly to apply PWM light modulation to LED, note that a current higher than the set LED current transiently flows.

○Selection of switching MOSFET transistors

There will be no problem for switching MOSFET transistors having absolute maximum rating higher than rated current of the inductor L and VF higher than " $C_{OUT}$  breakdown voltage + Rectifier diode". However, to achieve high-speed switching, select transistors with small gate capacity (injected charge amount).

Note: Rated current larger than overcurrent protection setting current is recommended.

Note: Selecting transistors with low on resistance can obtain high efficiency.

○Selection of rectifier diodes

Select Schottky barrier diodes having current capability higher than the rated current of the inductor L and inverse breakdown voltage higher than  $C_{OUT}$  breakdown voltage, particularly having low forward voltage VF.

○Selection of Load switch MOSFET and soft start function

In usual DC/DC converter, because there is no switching to a path leading from  $V_{IN}$  to  $V_{OUT}$  resulting in output voltage is also occur even if IC is in OFF state. Please insert PMOSFET between  $V_{IN}$  and inductor if you want voltage to 0V until the IC starts to operate. In addition, FAIL pin can be used for driving load switch after confirmed the logic theory, and the breakdown voltage of drain-source needed to be selected larger than  $V_{IN}$ .

Furthermore, if you would like to make soft start function to load switch, please insert a condenser between Gate and Source.

### ●Phase Compensation Setting Procedure

DC/DC converter application for current mode control includes one each of pole  $f_p$  (phase delay) by CR filter consisting of output capacitor and output resistor (i.e., LED current) and zero (phase lead)  $f_z$  by the output capacitor and capacitor ESR.

Furthermore, the step-up DC/DC converter includes RHP zero “ $f_{ZRHP}$ ” as the second zero. Since the RHP zero has phase delay ( $-90^\circ$ ) characteristics like the pole, the crossover frequency  $f_c$  should be set to not more than RHP zero.

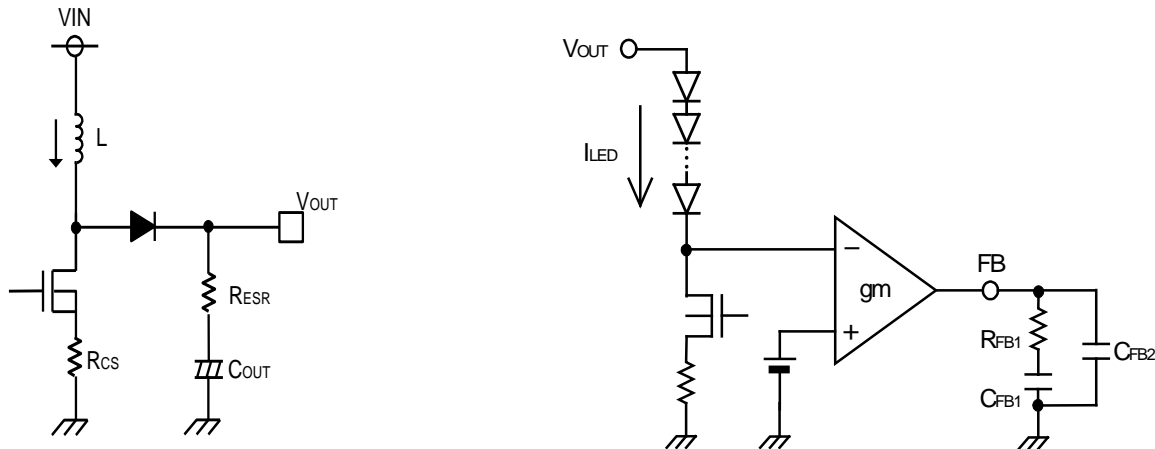

- i. Find Pole  $f_p$  and RHP zero  $f_{ZRHP}$  of DC/DC converter.

$$f_p = \frac{I_{LED}}{2\pi \times V_{OUT} \times C_{OUT}} [Hz] \quad f_{ZRHP} = \frac{V_{OUT} \times (1-D)^2}{2\pi \times L \times I_{LED}} [Hz]$$

Here,  $I_{LED}$  = LED Total current[A],  $D = \frac{V_{OUT} - V_{IN}}{V_{OUT}}$

- ii. Find phase compensation to be inserted to error amplifier. (set  $f_c$  is 1/5 to  $f_{ZRHP}$ )

$$R_{FB1} = \frac{f_{RHZP} \times R_{CS} \times I_{LED}}{5 \times f_p \times gm \times V_{OUT} \times (1-D)} [\Omega] \quad C_{FB1} = \frac{1}{2\pi \times R_{FB1} \times f_p} [F]$$

Here,  $gm = 4.0 \times 10^{-4} [S]$

- iii. Find zero used to compensate ESR ( $R_{ESR}$ ) of  $C_{OUT}$  (electrolytic capacitor).

$$C_{FB2} = \frac{R_{ESR} \times C_{OUT}}{R_{FB1}} [F]$$

※Even if a ceramic capacitor ( $R_{ESR}$  of the order of milliohms) for  $C_{OUT}$ , it is recommended to insert  $C_{FB2}$  for stable operation.

To improve transient response, it is necessary to increase  $R_{FB1}$  and reduce  $C_{FB1}$ . However, this improvement reduces a phase margin. To avoid this problem, conduct thorough verification, including variations in external components, on practical systems.

●The setting of REG75 capacity and shutdown procedure

VOUT discharge function is built-in this IC when IC is shutdown, the below describes the operation sequence.

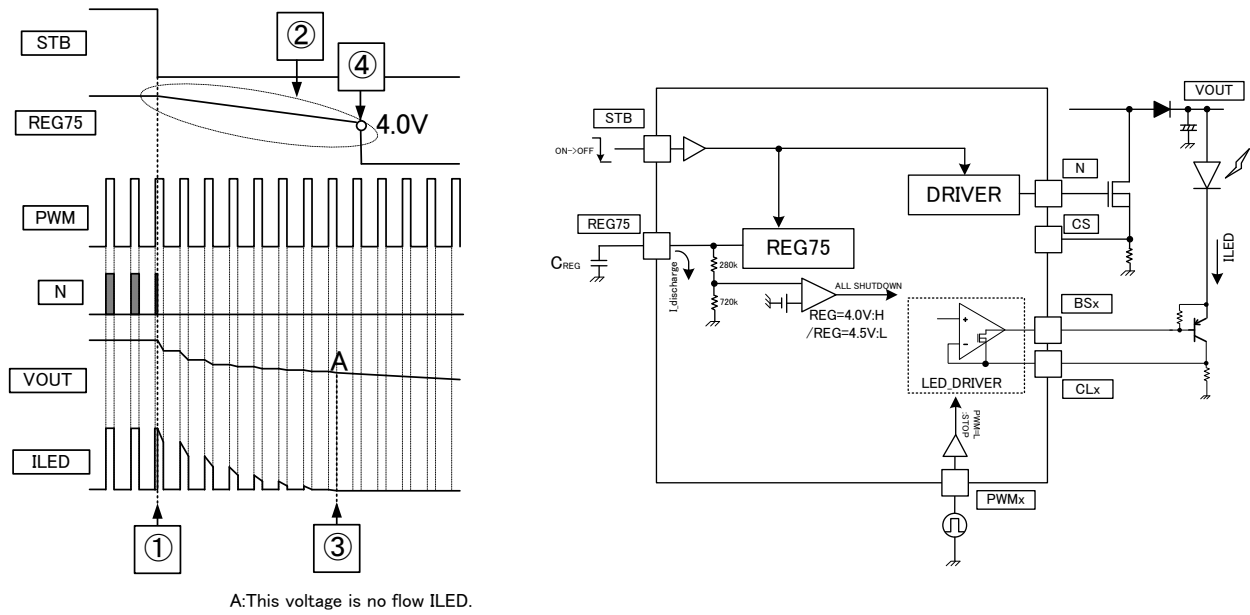

Figure 14. Timing chart of shutdown

○Explanation of shutdown sequence

- ① Set STB pin to “OFF” will stop DC/DC converter and REG75, but LED driver will remain operation.
- ② Discharge the REG75 pin voltage from 7.5V to 4.0V with 1MΩ.
- ③ The VOUT voltage will be discharged with ILED current and the discharged VOUT voltage is no flow ILED current.
- ④ When REG75 pin voltage will reach 4.0V (Typ.) or less to shut down all systems

○REG75 capacitance setting procedure

The shutdown time “T<sub>OFF</sub>” can be calculated by the following equation.

$$T_{OFF} [\text{sec}] = C_{REG} [\text{F}] \cdot R_{REG} [\Omega] \cdot \ln \frac{REG75_{t=0} [\text{V}]}{REG75_{UVLO} [\text{V}]} = C_{REG} [\text{F}] \cdot 1 [\text{M}\Omega] \cdot \ln \frac{7.5 [\text{V}]}{4.0 [\text{V}]} = 628.6 \cdot 10^3 \cdot C_{REG} [\text{sec}]$$

The longest VOUT discharge time will be obtained when the PWM duty cycle is set to the minimum VOUT. Make REG capacitance setting with an adequate margin so that systems will be shut off after VOUT voltage is fully discharged.

●Timing Chart

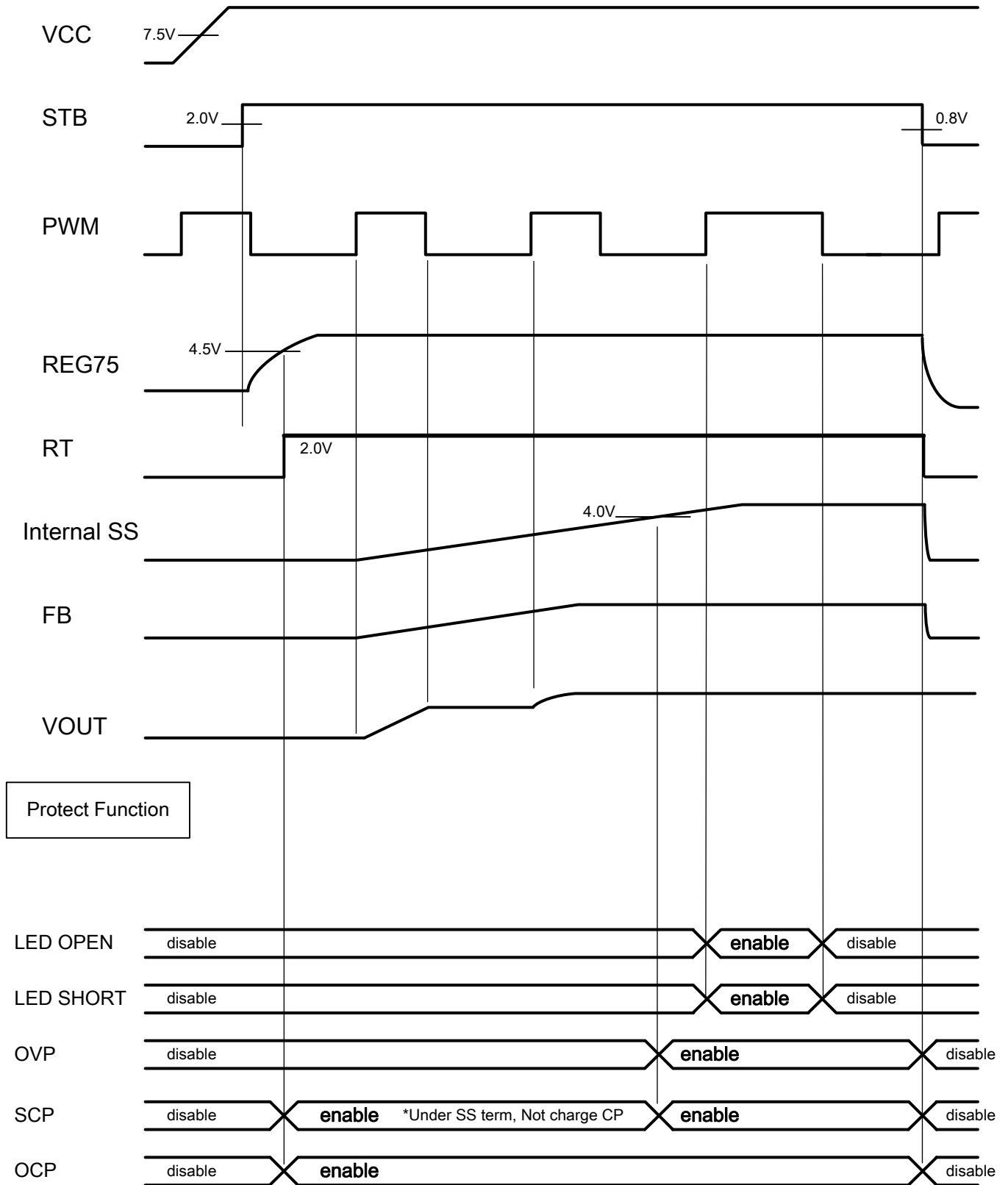

### ●List of Protection Functions

○List of protection detecting condition

Protection names	Detection	Detection condition			Release condition	Timer	Protection type
	pin	Detection pin condition	PWM	SS			
LED OPEN	BSx	BSx < 0.1V	H(Pulse over 4CLK)	SS>4.0V	BSx > 0.1V	2 <sup>15</sup> count	Latch(Only detected ch)
	CLx	CLx < 0.1V	H(Pulse over 4CLK)	SS>4.0V	CLx > 0.1V		
LED SHORT	BSx	BSx > 9V	H(Pulse over 4CLK)	SS>4.0V	BSx < 9V	2 <sup>15</sup> count	Latch(Only detected ch)
LED GND SHORT	BSx	BSx < 0.1V	H(Pulse over 4CLK)	SS>4.0V	BSx > 0.1V	2 <sup>15</sup> +2 <sup>7</sup> count	Latch
RT GND SHORT	RT	Under RT x90%	-	-	Canceled RT=GND State	Immediately detect	Auto-restart
VCC UVLO	VCC	VCC < 7.2V	-	-	VCC>7.5V	Immediately detect	Auto-restart
REG75 UVLO	REG75	REG75 < 4.0V	-	-	REG75>4.5V	Immediately detect	Auto-restart
OVP	OVP	OVP>3.0V	-	-	OVP<2.8V	2 <sup>18</sup> count	Latch
SCP	OVP	OVP < 0.1V	-	-	OVP > 0.1V	2 <sup>15</sup> count	Latch
OCP	CS	CS>0.4V	-	-	CS<0.4V	Immediately detect	Pulse by Pulse

- To clear the latch type, STB should be set to "L" once, and then to "H".
- The count of Timer means "1count=1duty of switching frequency."

○List of protection detecting operation

Protection Functions	Operation when the hysteresis type protection is detected			
	DC/DC	LED Driver	Soft start	RT pin
LED OPEN	Stops operating after CP counting	Only detected LED stops operating after CP counting	Low after all ch Latch	Low after all ch Latch
LED SHORT	Stops operating after CP counting	Only detected LED stops operating after CP counting	Low after all ch Latch	Low after all ch Latch
LED GND SHORT	Stops operating after CP counting	Stops operating after CP counting	Discharge after CP counting	Low after CP counting
RT GND SHORT	Instantaneously stops operating	Instantaneously stops operating	Not discharged	-
VCC UVLO	Instantaneously stops operating	Instantaneously stops operating	Discharge	Normal operation
REG75 UVLO	Instantaneously stops operating	Instantaneously stops operating	Discharge	Normal operation
OVP	Instantaneously stops operating	Stops operating after CP counting	Discharge after CP counting	Low after CP counting
SCP	N output stops	Stops operating after CP counting	Discharge after CP counting	Low after CP counting
OCP	Limits duty cycle	Normal operation	Not discharged	Normal operation

<Example>

Case FOSC=150kHz

○LED OPEN,LED SHORT,SCP

32768count→Latch after 218.5msec

○LED GND SHORT

32896count→Latch after 219.3msec

○OVP

262144count→Latch after 1.748sec

○Soft Start time

12480count→83.2msec

○Timing of Error detection (Common phase PWM dimming)

This IC is individual Latch OFF. Therefore, Error detection is every channel.

The detection timing of LED OPEN, SHORT and GND SHORT Protection is different with PWM Duty or Timing of Error state as follows:

(A).Other channels will be in Error states within 4counts of internal CLK. [When PWMA and PWMB and PWMC =100%]

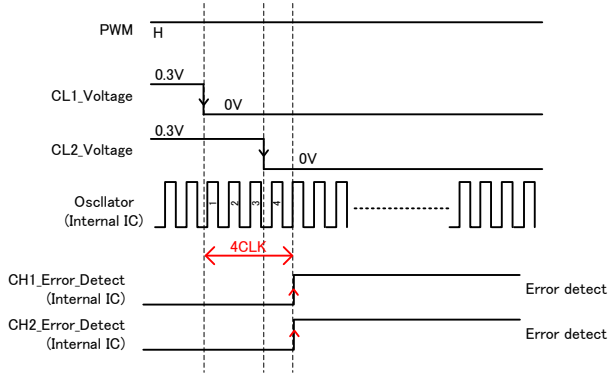

※Error detection is same timing.

(B).Other channels will be in Error states after 4counts of internal CLK. [When PWMA and PWMB and PWMC =100%]

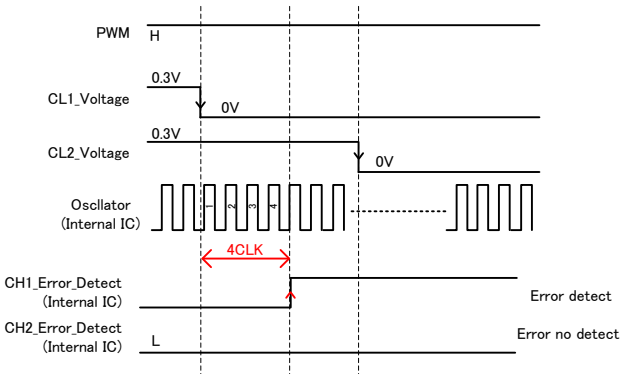

※Error detection is only first Error state channel.

(C).Other channels will be in Error states after 4counts of internal CLK. [When PWMA and PWMB and PWMC = common phase dimming and when except PWM=100%]

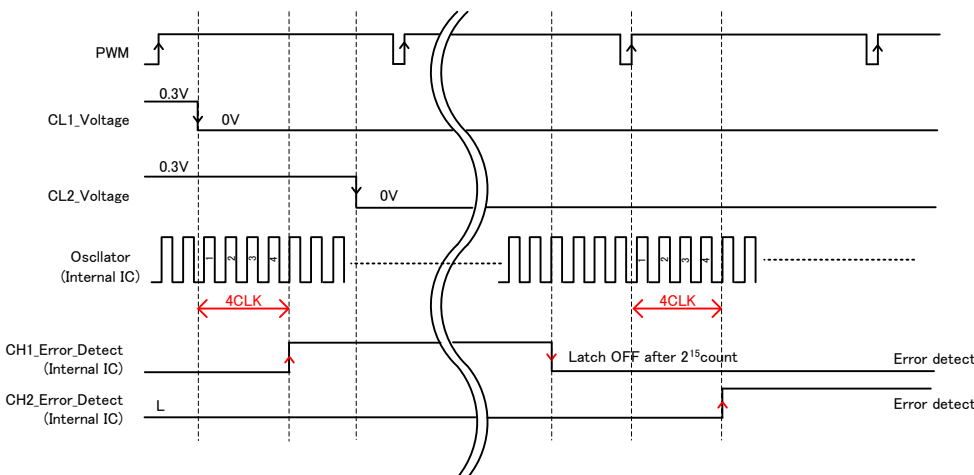

※First Error state channel is Latch OFF. Then, the detection of the following channel can detect whenever the new edge of PWM comes. Finally, all Error state channels are Latch off.



○Timing of Error detection (Phase shift PWM dimming)

The error detection timing at phase shift of PWM input is as follows

In this timing chart, the condition is SEL=L. (PWMA=CH1~CH3 control, PWMC=CH4~CH6 control)

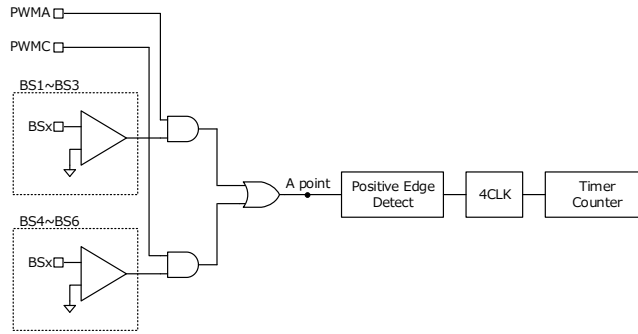

(A). Other channels will be in Error states after 4counts of internal CLK.  
[When there is not the condition becoming PWMA=L and PWMC=L.]

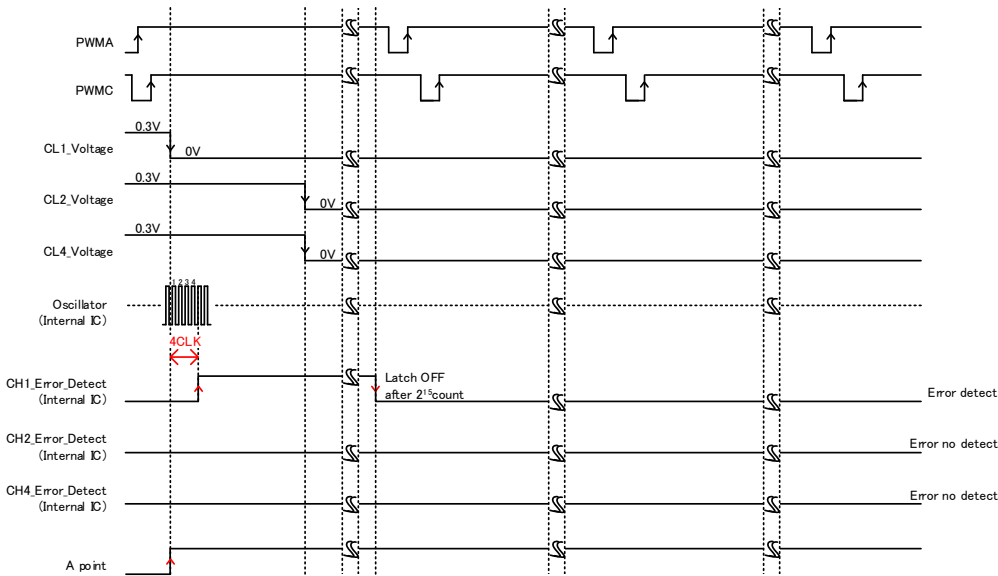

※Error detection is only first Error state channel.

(Because there is not the condition becoming PWMA=L and PWMC=L, the new edge of the PWM does not come to A point.)

(B). Other channels will be in Error states after 4counts of internal CLK.  
[When there is the condition becoming PWMA=L and PWMC=L]

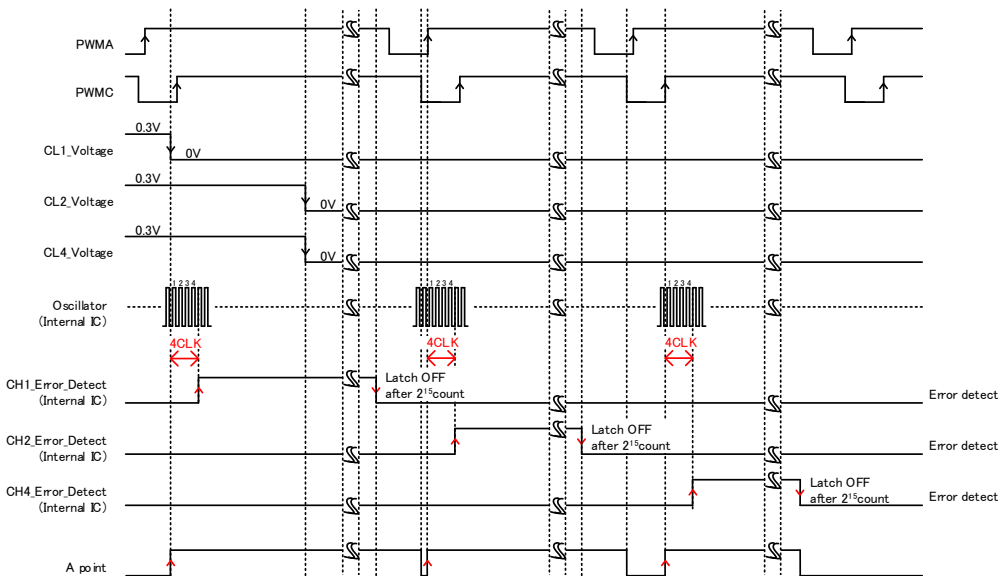

※First Error state channel is Latch OFF. Then, the detection of the following channel can detect whenever the new edge of PWM comes. Finally, all Error state channels are Latch off.

## Operational Notes

### 1. Reverse Connection of Power Supply

Connecting the power supply in reverse polarity can damage the IC. Take precautions against reverse polarity when connecting the power supply, such as mounting an external diode between the power supply and the IC's power supply terminals.

### 2. Power Supply Lines

Design the PCB layout pattern to provide low impedance supply lines. Separate the ground and supply lines of the digital and analog blocks to prevent noise in the ground and supply lines of the digital block from affecting the analog block. Furthermore, connect a capacitor to ground at all power supply pins. Consider the effect of temperature and aging on the capacitance value when using electrolytic capacitors.

### 3. Ground Voltage

Ensure that no pins are at a voltage below that of the ground pin at any time, even during transient condition.

### 4. Ground Wiring Pattern

When using both small-signal and large-current ground traces, the two ground traces should be routed separately but connected to a single ground at the reference point of the application board to avoid fluctuations in the small-signal ground caused by large currents. Also ensure that the ground traces of external components do not cause variations on the ground voltage. The ground lines must be as short and thick as possible to reduce line impedance.

### 5. Thermal Consideration

Should by any chance the power dissipation rating be exceeded the rise in temperature of the chip may result in deterioration of the properties of the chip. The absolute maximum rating of the Pd stated in this specification is when the IC is mounted on a 70mm x 70mm x 1.6mm glass epoxy board. In case of exceeding this absolute maximum rating, increase the board size and copper area to prevent exceeding the Pd rating.

### 6. Recommended Operating Conditions

These conditions represent a range within which the expected characteristics of the IC can be approximately obtained. The electrical characteristics are guaranteed under the conditions of each parameter.

### 7. Inrush Current

When power is first supplied to the IC, it is possible that the internal logic may be unstable and inrush current may flow instantaneously due to the internal powering sequence and delays, especially if the IC has more than one power supply. Therefore, give special consideration to power coupling capacitance, power wiring, width of ground wiring, and routing of connections.

### 8. Testing on Application Boards

When testing the IC on an application board, connecting a capacitor directly to a low-impedance output pin may subject the IC to stress. Always discharge capacitors completely after each process or step. The IC's power supply should always be turned off completely before connecting or removing it from the test setup during the inspection process. To prevent damage from static discharge, ground the IC during assembly and use similar precautions during transport and storage.

### 9. Inter-pin Short and Mounting Errors

Ensure that the direction and position are correct when mounting the IC on the PCB. Incorrect mounting may result in damaging the IC. Avoid nearby pins being shorted to each other especially to ground, power supply and output pin. Inter-pin shorts could be due to many reasons such as metal particles, water droplets (in very humid environment) and unintentional solder bridge deposited in between pins during assembly to name a few.

## Operational Notes – continued

**10. Unused Input Terminals**

Input terminals of an IC are often connected to the gate of a MOS transistor. The gate has extremely high impedance and extremely low capacitance. If left unconnected, the electric field from the outside can easily charge it. The small charge acquired in this way is enough to produce a significant effect on the conduction through the transistor and cause unexpected operation of the IC. So unless otherwise specified, unused input terminals should be connected to the power supply or ground line.

**11. Regarding the Input Pin of the IC**

This monolithic IC contains P+ isolation and P substrate layers between adjacent elements in order to keep them isolated. P-N junctions are formed at the intersection of the P layers with the N layers of other elements, creating a parasitic diode or transistor. For example (refer to figure below):

When  $GND > Pin A$  and  $GND > Pin B$ , the P-N junction operates as a parasitic diode.

When  $GND > Pin B$ , the P-N junction operates as a parasitic transistor.

Parasitic diodes inevitably occur in the structure of the IC. The operation of parasitic diodes can result in mutual interference among circuits, operational faults, or physical damage. Therefore, conditions that cause these diodes to operate, such as applying a voltage lower than the GND voltage to an input pin (and thus to the P substrate) should be avoided.

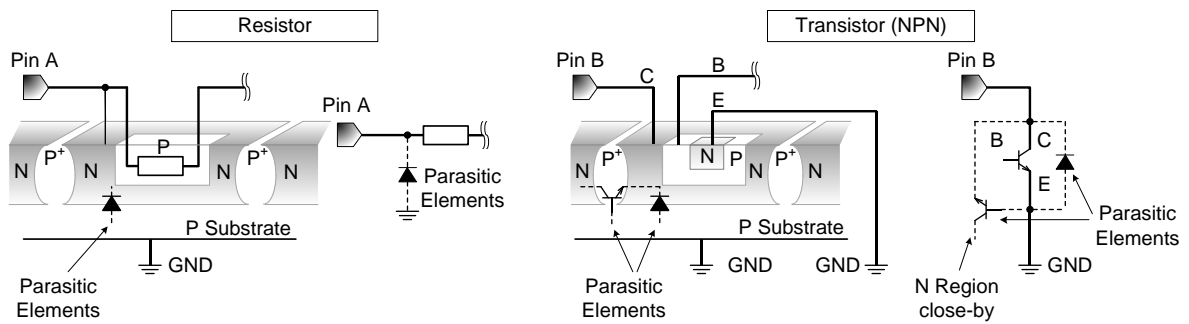

Figure 15. Example of monolithic IC structure

**12. Ceramic Capacitor**

When using a ceramic capacitor, determine the dielectric constant considering the change of capacitance with temperature and the decrease in nominal capacitance due to DC bias and others.

**13. Area of Safe Operation (ASO)**

Operate the IC such that the output voltage, output current, and power dissipation are all within the Area of Safe Operation (ASO).

**14. Thermal Shutdown Circuit(TSD)**

This IC has a built-in thermal shutdown circuit that prevents heat damage to the IC. Normal operation should always be within the IC's power dissipation rating. If however the rating is exceeded for a continued period, the junction temperature ( $T_j$ ) will rise which will activate the TSD circuit that will turn OFF all output pins. When the  $T_j$  falls below the TSD threshold, the circuits are automatically restored to normal operation.

Note that the TSD circuit operates in a situation that exceeds the absolute maximum ratings and therefore, under no circumstances, should the TSD circuit be used in a set design or for any purpose other than protecting the IC from heat damage.

**15. Over Current Protection Circuit (OCP)**

This IC incorporates an integrated overcurrent protection circuit that is activated when the load is shorted. This protection circuit is effective in preventing damage due to sudden and unexpected incidents. However, the IC should not be used in applications characterized by continuous operation or transitioning of the protection circuit.

## Status of this document

The Japanese version of this document is formal specification. A customer may use this translation version only for a reference to help reading the formal version.

If there are any differences in translation version of this document formal version takes priority

Ordering Information

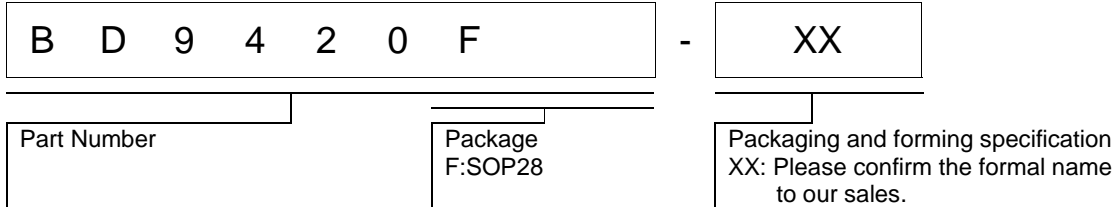

Physical Dimension, Tape and Reel Information

SOP28

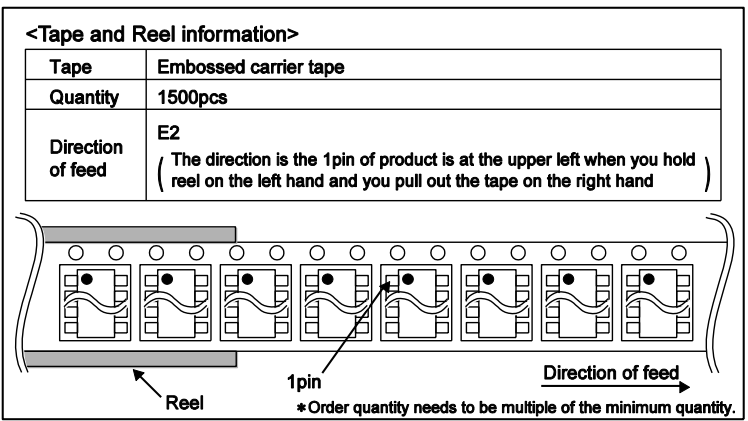
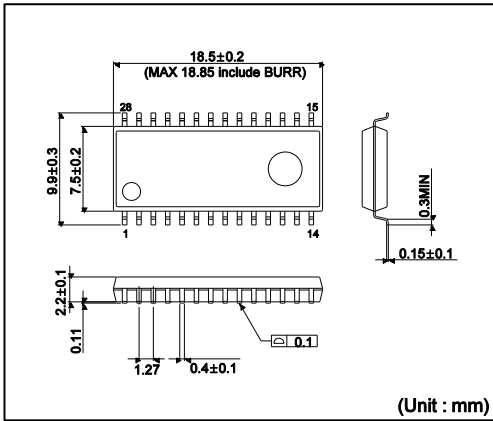

## Revision History

Date	Revision	Changes
11.Nov.2013	001	New Release
31.Jan.2014	002	P15. Timing chart of Timer count add
		P23. Detection condition add
		P24. Timing of Error detection add
25.Sep.2015	003	P2. External Component Recommended Range add
		P8. No use channel setting add
		P23. Protection condition change
20.Jun.2017	004	P.24. Timing of Error detection (PWM dimming condition) add
		P.25. Timing of Error detection (phase shift PWM dimming) add

# Notice

## Precaution on using ROHM Products

- Our Products are designed and manufactured for application in ordinary electronic equipments (such as AV equipment, OA equipment, telecommunication equipment, home electronic appliances, amusement equipment, etc.). If you intend to use our Products in devices requiring extremely high reliability (such as medical equipment <sup>(Note 1)</sup>, transport equipment, traffic equipment, aircraft/spacecraft, nuclear power controllers, fuel controllers, car equipment including car accessories, safety devices, etc.) and whose malfunction or failure may cause loss of human life, bodily injury or serious damage to property ("Specific Applications"), please consult with the ROHM sales representative in advance. Unless otherwise agreed in writing by ROHM in advance, ROHM shall not be in any way responsible or liable for any damages, expenses or losses incurred by you or third parties arising from the use of any ROHM's Products for Specific Applications.

(Note1) Medical Equipment Classification of the Specific Applications

JAPAN	USA	EU	CHINA
CLASS III	CLASS III	CLASS II b	CLASS III
CLASS IV		CLASS III	

- ROHM designs and manufactures its Products subject to strict quality control system. However, semiconductor products can fail or malfunction at a certain rate. Please be sure to implement, at your own responsibilities, adequate safety measures including but not limited to fail-safe design against the physical injury, damage to any property, which a failure or malfunction of our Products may cause. The following are examples of safety measures:
  - Installation of protection circuits or other protective devices to improve system safety
  - Installation of redundant circuits to reduce the impact of single or multiple circuit failure
- Our Products are designed and manufactured for use under standard conditions and not under any special or extraordinary environments or conditions, as exemplified below. Accordingly, ROHM shall not be in any way responsible or liable for any damages, expenses or losses arising from the use of any ROHM's Products under any special or extraordinary environments or conditions. If you intend to use our Products under any special or extraordinary environments or conditions (as exemplified below), your independent verification and confirmation of product performance, reliability, etc. prior to use, must be necessary:
  - Use of our Products in any types of liquid, including water, oils, chemicals, and organic solvents
  - Use of our Products outdoors or in places where the Products are exposed to direct sunlight or dust
  - Use of our Products in places where the Products are exposed to sea wind or corrosive gases, including Cl<sub>2</sub>, H<sub>2</sub>S, NH<sub>3</sub>, SO<sub>2</sub>, and NO<sub>2</sub>
  - Use of our Products in places where the Products are exposed to static electricity or electromagnetic waves
  - Use of our Products in proximity to heat-producing components, plastic cords, or other flammable items
  - Sealing or coating our Products with resin or other coating materials
  - Use of our Products without cleaning residue of flux (even if you use no-clean type fluxes, cleaning residue of flux is recommended); or Washing our Products by using water or water-soluble cleaning agents for cleaning residue after soldering
  - Use of the Products in places subject to dew condensation
- The Products are not subject to radiation-proof design.
- Please verify and confirm characteristics of the final or mounted products in using the Products.
- In particular, if a transient load (a large amount of load applied in a short period of time, such as pulse. is applied, confirmation of performance characteristics after on-board mounting is strongly recommended. Avoid applying power exceeding normal rated power; exceeding the power rating under steady-state loading condition may negatively affect product performance and reliability.
- De-rate Power Dissipation depending on ambient temperature. When used in sealed area, confirm that it is the use in the range that does not exceed the maximum junction temperature.
- Confirm that operation temperature is within the specified range described in the product specification.
- ROHM shall not be in any way responsible or liable for failure induced under deviant condition from what is defined in this document.

## Precaution for Mounting / Circuit board design

- When a highly active halogenous (chlorine, bromine, etc.) flux is used, the residue of flux may negatively affect product performance and reliability.
- In principle, the reflow soldering method must be used on a surface-mount products, the flow soldering method must be used on a through hole mount products. If the flow soldering method is preferred on a surface-mount products, please consult with the ROHM representative in advance.

For details, please refer to ROHM Mounting specification

### Precautions Regarding Application Examples and External Circuits

1. If change is made to the constant of an external circuit, please allow a sufficient margin considering variations of the characteristics of the Products and external components, including transient characteristics, as well as static characteristics.
2. You agree that application notes, reference designs, and associated data and information contained in this document are presented only as guidance for Products use. Therefore, in case you use such information, you are solely responsible for it and you must exercise your own independent verification and judgment in the use of such information contained in this document. ROHM shall not be in any way responsible or liable for any damages, expenses or losses incurred by you or third parties arising from the use of such information.

### Precaution for Electrostatic

This Product is electrostatic sensitive product, which may be damaged due to electrostatic discharge. Please take proper caution in your manufacturing process and storage so that voltage exceeding the Products maximum rating will not be applied to Products. Please take special care under dry condition (e.g. Grounding of human body / equipment / solder iron, isolation from charged objects, setting of Ionizer, friction prevention and temperature / humidity control).

### Precaution for Storage / Transportation

1. Product performance and soldered connections may deteriorate if the Products are stored in the places where:
  - [a] the Products are exposed to sea winds or corrosive gases, including Cl<sub>2</sub>, H<sub>2</sub>S, NH<sub>3</sub>, SO<sub>2</sub>, and NO<sub>2</sub>
  - [b] the temperature or humidity exceeds those recommended by ROHM
  - [c] the Products are exposed to direct sunshine or condensation
  - [d] the Products are exposed to high Electrostatic
2. Even under ROHM recommended storage condition, solderability of products out of recommended storage time period may be degraded. It is strongly recommended to confirm solderability before using Products of which storage time is exceeding the recommended storage time period.
3. Store / transport cartons in the correct direction, which is indicated on a carton with a symbol. Otherwise bent leads may occur due to excessive stress applied when dropping of a carton.
4. Use Products within the specified time after opening a humidity barrier bag. Baking is required before using Products of which storage time is exceeding the recommended storage time period.

### Precaution for Product Label

A two-dimensional barcode printed on ROHM Products label is for ROHM's internal use only.

### Precaution for Disposition

When disposing Products please dispose them properly using an authorized industry waste company.

### Precaution for Foreign Exchange and Foreign Trade act

Since concerned goods might be fallen under listed items of export control prescribed by Foreign exchange and Foreign trade act, please consult with ROHM in case of export.

### Precaution Regarding Intellectual Property Rights

1. All information and data including but not limited to application example contained in this document is for reference only. ROHM does not warrant that foregoing information or data will not infringe any intellectual property rights or any other rights of any third party regarding such information or data.
2. ROHM shall not have any obligations where the claims, actions or demands arising from the combination of the Products with other articles such as components, circuits, systems or external equipment (including software).
3. No license, expressly or implied, is granted hereby under any intellectual property rights or other rights of ROHM or any third parties with respect to the Products or the information contained in this document. Provided, however, that ROHM will not assert its intellectual property rights or other rights against you or your customers to the extent necessary to manufacture or sell products containing the Products, subject to the terms and conditions herein.

### Other Precaution

1. This document may not be reprinted or reproduced, in whole or in part, without prior written consent of ROHM.
2. The Products may not be disassembled, converted, modified, reproduced or otherwise changed without prior written consent of ROHM.
3. In no event shall you use in any way whatsoever the Products and the related technical information contained in the Products or this document for any military purposes, including but not limited to, the development of mass-destruction weapons.
4. The proper names of companies or products described in this document are trademarks or registered trademarks of ROHM, its affiliated companies or third parties.

**General Precaution**

1. Before you use our Products, you are requested to carefully read this document and fully understand its contents. ROHM shall not be in any way responsible or liable for failure, malfunction or accident arising from the use of any ROHM's Products against warning, caution or note contained in this document.
2. All information contained in this document is current as of the issuing date and subject to change without any prior notice. Before purchasing or using ROHM's Products, please confirm the latest information with a ROHM sales representative.
3. The information contained in this document is provided on an "as is" basis and ROHM does not warrant that all information contained in this document is accurate and/or error-free. ROHM shall not be in any way responsible or liable for any damages, expenses or losses incurred by you or third parties resulting from inaccuracy or errors of or concerning such information.