

## Evaluation Board for Single, High Speed Operational Amplifiers (8-Lead SOIC with Dedicated Feedback Pin and Exposed Paddle)

### FEATURES

- Enables quick breadboarding/prototyping**
- User-defined circuit configuration**
- Edge-mounted SMA connector provisions**
- Easy connection to test equipment and other circuits**

### GENERAL DESCRIPTION

The 8-lead standard small outline package (SOIC), with a dedicated feedback pin and an exposed paddle, evaluation board is designed to aid in the evaluation of single, high speed operational amplifiers. The evaluation board is a bare board (that is, there are no components soldered to the board) that enables users to quickly prototype a variety of operational amplifier circuits, which minimizes risk and reduces time to market. The evaluation board supports any of the Analog Devices, Inc., single, high speed operational amplifiers in an 8-lead SOIC package with a dedicated feedback pin and an exposed paddle.

Figure 1 shows the component side of the evaluation board, and Figure 2 shows the circuit side of the evaluation board. Figure 3 shows the evaluation board schematic.

The 4-layer evaluation board accepts edge-mounted Subminiature Version A (SMA) connectors on both inputs and outputs, which allows efficient and quick connection to test equipment or other circuitry.

The board ground plane, component placement, and power supply bypassing are optimized for maximum circuit flexibility and performance. The evaluation board uses a variety of surface-mount technology (SMT) component case sizes: 0402, 0508, 0603, and 7343.

Figure 4 and Figure 6 show the evaluation board assembly drawings. The metal layout pattern for connecting the board to the op amp and to the supporting circuitry is shown in Figure 5 and Figure 7.

### EVALUATION BOARD COMPONENT SIDE AND CIRCUIT SIDE DIAGRAMS

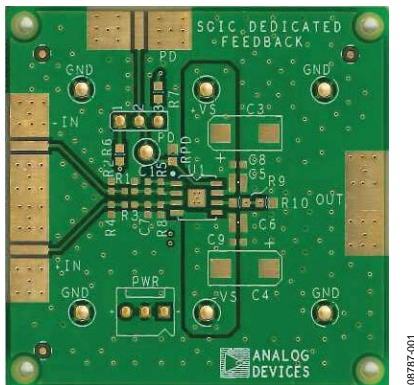

Figure 1. Component Side of the Evaluation Board

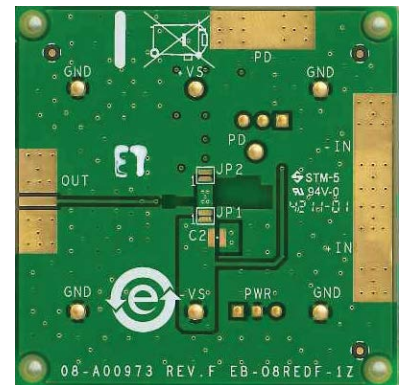

Figure 2. Circuit Side of the Evaluation Board

**TABLE OF CONTENTS**

Features .....	1	Noninverting Configuration.....	5
General Description .....	1	Ordering Information.....	6
Evaluation Board Component Side and Circuit Side Diagrams	1	Bill of Materials.....	6
Revision History .....	2		
Evaluation Board Schematic, Assembly Drawings, and Board Layouts .....	3		

**REVISION HISTORY**

**12/12—Rev. A to Rev. B**

Changes to General Description, Figure 1, and Figure 2 .....	1
Changes to Figure 4 to Figure 7 .....	4

**3/10—Rev. 0 to Rev. A**

Changed EB-O8RE-1Z to EB-O8REDF-1Z.....	Throughout
Added Noninverting Configuration Section .....	5
Added Ordering Information Section .....	6

**2/10—Revision 0: Initial Version**

# EVALUATION BOARD SCHEMATIC, ASSEMBLY DRAWINGS, AND BOARD LAYOUTS

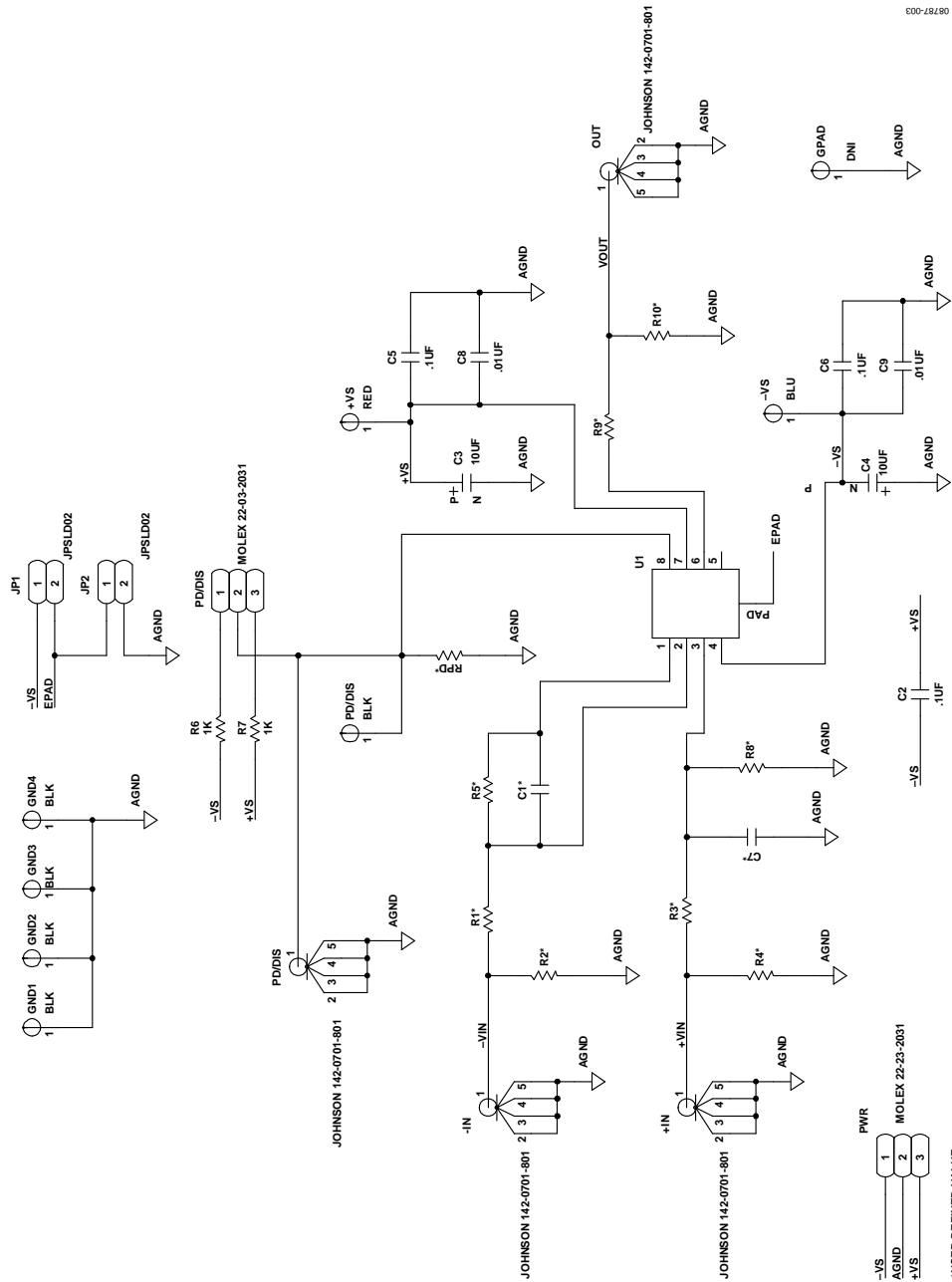

Figure 3. Evaluation Board Schematic

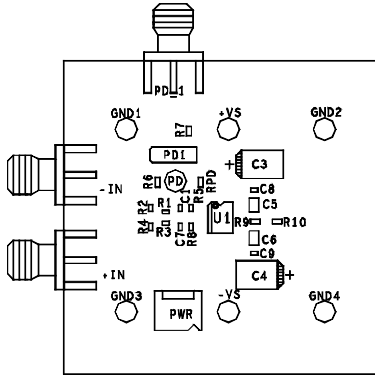

Figure 4. Board Assembly Drawing, Component Side

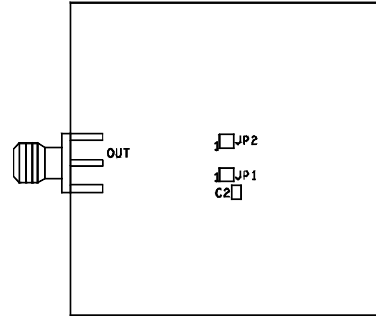

Figure 6. Board Assembly Drawing, Circuit Side

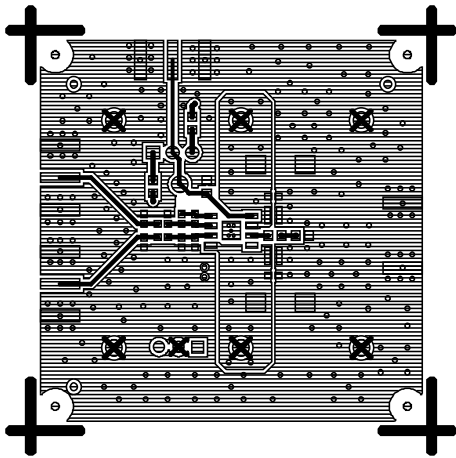

Figure 5. Board Layout Pattern, Component Side

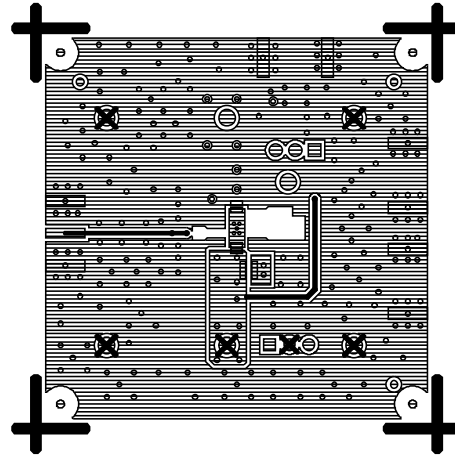

Figure 7. Board Layout Pattern, Circuit Side

## NONINVERTING CONFIGURATION

When using this board in a noninverting configuration, with a gain larger than 1, there are two recommended ways to place the gain resistor. The first way is to place the gain resistor in the R1 location and uses a  $0\ \Omega$  for the R2 location to short to ground. The second way is to place the gain resistor between the first pad of R1 and ground, without using a second resistor (see Figure 8).

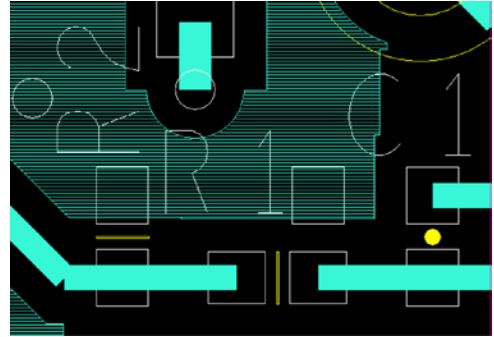

Figure 8. Noninverting Configuration with a Gain of Higher Than 1

**ORDERING INFORMATION****BILL OF MATERIALS**

Table 1.

Quantity	Reference Designator	Description	Package
3	+IN, -IN, OUT	Subminiature Version A/surface-mount technology	SMA/SMT
2	C1, C7	User-defined capacitors	C0402
2	C8, C9	0.01 $\mu$ F capacitors	C0402
3	C2, C5, C6	0.1 $\mu$ F capacitors	C0508
2	C3, C4	10 $\mu$ F capacitors	C6032
6	R1, R2, R3, R4, R5, R8	User-defined resistors	R0402
3	R9, R10, RPD	User-defined resistors	R0603
2	R6, R7	1 k $\Omega$ resistors	R0603
7	PD/DIS, GND1, GND2, GND3, GND4, +VS, -VS	Test points	TP
1	PWR	Header 3 POS	Molex 22-23-2031
1	PD/DIS	3-pin straight header	Molex 22-03-2031
2	JP1, JP2	User-defined jumpers	Solder jumper
1	U1	Amplifier	8-lead SOIC

**NOTES**

## NOTES

**ESD Caution**

**ESD (electrostatic discharge) sensitive device.** Charged devices and circuit boards can discharge without detection. Although this product features patented or proprietary protection circuitry, damage may occur on devices subjected to high energy ESD. Therefore, proper ESD precautions should be taken to avoid performance degradation or loss of functionality.

**Legal Terms and Conditions**

By using the evaluation board discussed herein (together with any tools, components documentation or support materials, the "Evaluation Board"), you are agreeing to be bound by the terms and conditions set forth below ("Agreement") unless you have purchased the Evaluation Board, in which case the Analog Devices Standard Terms and Conditions of Sale shall govern. Do not use the Evaluation Board until you have read and agreed to the Agreement. Your use of the Evaluation Board shall signify your acceptance of the Agreement. This Agreement is made by and between you ("Customer") and Analog Devices, Inc. ("ADI"), with its principal place of business at One Technology Way, Norwood, MA 02062, USA. Subject to the terms and conditions of the Agreement, ADI hereby grants to Customer a free, limited, personal, temporary, non-exclusive, non-sublicensable, non-transferable license to use the Evaluation Board FOR EVALUATION PURPOSES ONLY. Customer understands and agrees that the Evaluation Board is provided for the sole and exclusive purpose referenced above, and agrees not to use the Evaluation Board for any other purpose. Furthermore, the license granted is expressly made subject to the following additional limitations: Customer shall not (i) rent, lease, display, sell, transfer, assign, sublicense, or distribute the Evaluation Board; and (ii) permit any Third Party to access the Evaluation Board. As used herein, the term "Third Party" includes any entity other than ADI, Customer, their employees, affiliates and in-house consultants. The Evaluation Board is NOT sold to Customer; all rights not expressly granted herein, including ownership of the Evaluation Board, are reserved by ADI. CONFIDENTIALITY. This Agreement and the Evaluation Board shall all be considered the confidential and proprietary information of ADI. Customer may not disclose or transfer any portion of the Evaluation Board to any other party for any reason. Upon discontinuation of use of the Evaluation Board or termination of this Agreement, Customer agrees to promptly return the Evaluation Board to ADI. ADDITIONAL RESTRICTIONS. Customer may not disassemble, decompile or reverse engineer chips on the Evaluation Board. Customer shall inform ADI of any occurred damages or any modifications or alterations it makes to the Evaluation Board, including but not limited to soldering or any other activity that affects the material content of the Evaluation Board. Modifications to the Evaluation Board must comply with applicable law, including but not limited to the RoHS Directive. TERMINATION. ADI may terminate this Agreement at any time upon giving written notice to Customer. Customer agrees to return to ADI the Evaluation Board at that time. LIMITATION OF LIABILITY. THE EVALUATION BOARD PROVIDED HEREUNDER IS PROVIDED "AS IS" AND ADI MAKES NO WARRANTIES OR REPRESENTATIONS OF ANY KIND WITH RESPECT TO IT. ADI SPECIFICALLY DISCLAIMS ANY REPRESENTATIONS, ENDORSEMENTS, GUARANTEES, OR WARRANTIES, EXPRESS OR IMPLIED, RELATED TO THE EVALUATION BOARD INCLUDING, BUT NOT LIMITED TO, THE IMPLIED WARRANTY OF MERCHANTABILITY, TITLE, FITNESS FOR A PARTICULAR PURPOSE OR NON-INFRINGEMENT OF INTELLECTUAL PROPERTY RIGHTS. IN NO EVENT WILL ADI AND ITS LICENSORS BE LIABLE FOR ANY INCIDENTAL, SPECIAL, INDIRECT, OR CONSEQUENTIAL DAMAGES RESULTING FROM CUSTOMER'S POSSESSION OR USE OF THE EVALUATION BOARD, INCLUDING BUT NOT LIMITED TO LOST PROFITS, DELAY COSTS, LABOR COSTS OR LOSS OF GOODWILL. ADI'S TOTAL LIABILITY FROM ANY AND ALL CAUSES SHALL BE LIMITED TO THE AMOUNT OF ONE HUNDRED US DOLLARS (\$100,000). EXPORT. Customer agrees that it will not directly or indirectly export the Evaluation Board to another country, and that it will comply with all applicable United States federal laws and regulations relating to exports. GOVERNING LAW. This Agreement shall be governed by and construed in accordance with the substantive laws of the Commonwealth of Massachusetts (excluding conflict of law rules). Any legal action regarding this Agreement will be heard in the state or federal courts having jurisdiction in Suffolk County, Massachusetts, and Customer hereby submits to the personal jurisdiction and venue of such courts. The United Nations Convention on Contracts for the International Sale of Goods shall not apply to this Agreement and is expressly disclaimed.