

CONTACT ORIENTATION ON ROLL

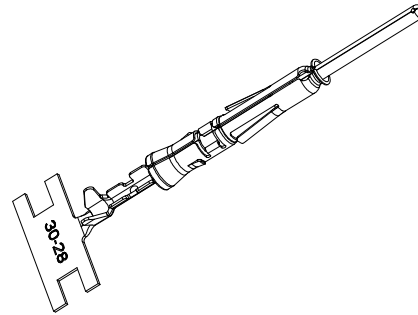

REVISIONS					
REV	ECO	DESCRIPTION	DATE	BY	APPR
B1	-	RELEASED DRAWING	AUG-18-2014	BEN	TOMMY
B2	-	CHANGE HAND CRIMPER	Nov-8-19	Flan	Tommy
B3	-	UPDATE DRAWING	Sep-01-22	Ronald	Tommy
B4	-	UPDATE THE HOOK	Jul-24-24	Joe	Tommy

NOTES: (UNLESS OTHERWISE SPECIFIED)

1. MATERIAL:
 - 1.1. CONTACT BODY: COPPER ALLOY.
 - 1.2. OUTER SPRING: STAINLESS STEEL.
2. SPECIFICATIONS:
 - 2.1 CURRENT RATING: 5A MAX.
 - 2.2 TERMINATION TYPE: CRIMPING.
 - 2.3 WIRE RANGE: 30~28AWG.
 - 2.4 WIRE INSULATION DIA(MAX): Ø1.8mm.
3. RoHS COMPLIANT.
4. ALL DIMENSIONS ARE FOR REFERENCE USE ONLY.
5. AVAILABLE TOOLS:
 - 5.1 HAND CRIMPER: MFX-3958.
 - 5.2 CRIMP APPLICATOR: MFX-3957.
 - 5.3 EXTRACTION TOOL: QXRT20.

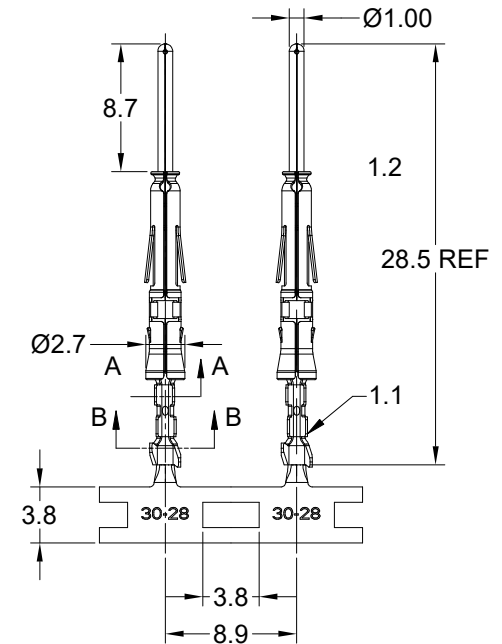
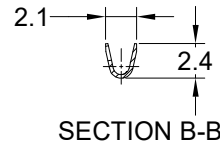
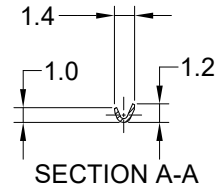

P/N	CONTACT PLATING(MATING AREA)
SP28W1T	TIN PLATING OVER NICKEL.
SP28W1F	GOLD FLASH PLATING OVER NICKEL.
SP28W1G5	5µ"GOLD PLATING OVER NICKEL.
SP28W1G10	10µ"GOLD PLATING OVER NICKEL.
SP28W1G15	15µ"GOLD PLATING OVER NICKEL.
SP28W1G30	30µ"GOLD PLATING OVER NICKEL.

QUANTITY	PART NUMBER	DESCRIPTION	ITEM
MATERIALS LIST			
<small>UNLESS OTHERWISE SPECIFIED</small> 1) All dimensions are in metric(mm). 2) Tolerances are as follows: 1 PL DEC ±0.30 Fractions ±1/64 2 PL DEC ±0.18 Angles ±1° 3 PL DEC ±0.08 3) Note reference =		SIGNATURES DATE DRAWN: Joe Jul-24-24 CHECKED: Orion Jul-24-24 ENGINEER: APPROVAL: Tommy Jul-25-24	 Sine Systems - www.amphenol-sine.com 44724 Morley Drive Clinton Township, MI 48036
MATERIAL SPECIFICATIONS: THIS DRAWING IS SUPPLIED FOR INFORMATION ONLY. DESIGN FEATURES, SPECIFICATIONS AND PERFORMANCE DATA SHOWN HEREON ARE THE PROPERTY OF THE AMPHENOL CORPORATION. NO RIGHTS OF REPRODUCTION ARE IMPLIED. ALL DIMENSIONS ARE SUBJECT TO NORMAL MANUFACTURING VARIATIONS.		CUSTOMER: ECO-MATE, PIN CONTACT STAMPED, 30-28AWG, SIZE 20	SIZE: B TYPE: C- DWG NO: SP28W1xx REVISION: B4 SCALE: NONE SHEET 1 OF 1
NEXT ASSY:			

TITLE: ECO-MATE PIN CONTACT, STAMPED, 30-28AWG, SIZE 20
 DWG NO: SP28W1xx
 REV: B4
 SH: 1
 OF: 1