

CONTACT ORIENTATION ON ROLL

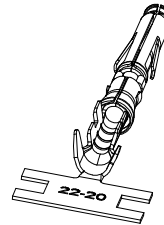

NOTES: (UNLESS OTHERWISE SPECIFIED)

1. MATERIAL:
 - 1.1. CONTACT BODY: COPPER ALLOY.
 - 1.2. OUTER SPRING: STAINLESS STEEL.
2. SPECIFICATIONS:
 - 2.1 CURRENT RATING: 5A MAX.
 - 2.2 TERMINATION TYPE: CRIMPING.
 - 2.3 WIRE RANGE: 18~22AWG.
 - 2.4 WIRE INSULATION DIA(MAX): Ø2.6mm.
3. RoHS COMPLIANT.
4. ALL DIMENSIONS ARE FOR REFERENCE USE ONLY.
5. AVAILABLE TOOLS:
 - 5.1 HAND CRIMPER: MFX-3958.
 - 5.2 CRIMP APPLICATOR: MFX-3957.
 - 5.3 EXTRACTION TOOL: QXRT20.

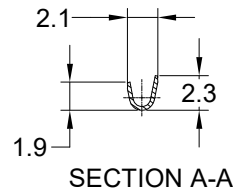

SECTION A-A

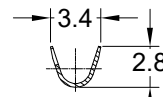

SECTION B-B

REVISIONS					
REV	ECO	DESCRIPTION	DATE	BY	APPR
B1	-	RELEASED DRAWING	JAN-18-2014	ARROW	TOMMY
B2	-	CHANGE HAND CRIMPER	Nov-8-19	Flan	Tommy
B3	-	UPDATE DRAWING	Sep-01-22	Ronald	Tommy
B4	-	CHANGE THE WIRE RANGE	Aug-09-23	Ronald	Tommy
B5	-	UPDATE THE HOOK	Jun-20-24	Joe	Tommy

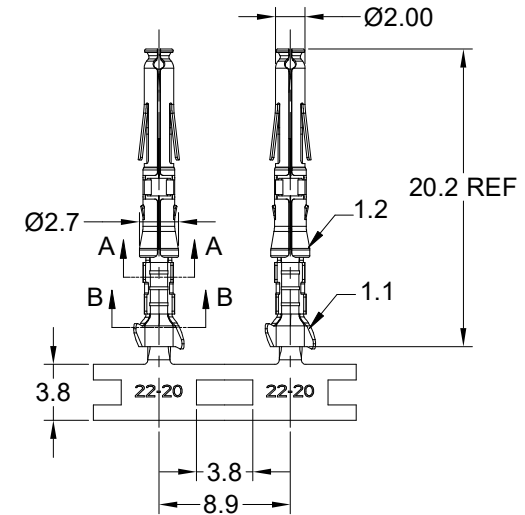

P/N	CONTACT PLATING(MATING AREA)
SS20W1T	TIN PLATING OVER NICKEL.
SS20W1F	GOLD FLASH PLATING OVER NICKEL.
SS20W1G10	10µ"GOLD PLATING OVER NICKEL.
SS20W1G15	15µ"GOLD PLATING OVER NICKEL.
SS20W1G30	30µ"GOLD PLATING OVER NICKEL.

QUANTITY	PART NUMBER	DESCRIPTION	ITEM
MATERIALS LIST			
UNLESS OTHERWISE SPECIFIED 1) All dimensions are in metric(mm). 2) Tolerances are as follows: 1 PL DEC ±0.30 2 PL DEC ±0.15 3 PL DEC ±0.08 Fractions ±1/64 Angles ±1° 3) Note reference =		SIGNATURES DATE DRAWN: Joe Jun-20-24 CHECKED: Oton Jun-20-24 ENGINEER: APPROVAL: Tommy Jun-21-24 CUSTOMER:	
MATERIAL SPECIFICATIONS: PROCESS SPECIFICATIONS: NEXT ASSY:		<div style="text-align: center;"> Sine Systems - www.amphenol-sine.com 44724 Morley Drive Clinton Township, MI 48036 </div> <div style="text-align: center;"> ECO-MATE, SOCKET CONTACT STAMPED, 18-22 AWG, SIZE 20 </div>	
THIS DRAWING IS SUPPLIED FOR INFORMATION ONLY. DESIGN FEATURES, SPECIFICATIONS AND PERFORMANCE DATA SHOWN HEREON ARE THE PROPERTY OF THE AMPHENOL CORPORATION. NO RIGHTS OF REPRODUCTION ARE IMPLIED. ALL DIMENSIONS ARE SUBJECT TO NORMAL MANUFACTURING VARIATIONS.		SIZE B C-	REVISION B5
SCALE: NONE		DWG NO.: SS20W1xx	SHEET 1 OF 1

TITLE: ECO-MATE, SOCKET CONTACT, STAMPED, 18-22 AWG, SIZE 20
 DWG NO.: SS20W1xx
 REV: B5
 SH: 1
 OF: 1