

DO NOT
SCALE FROM
THIS PRINT

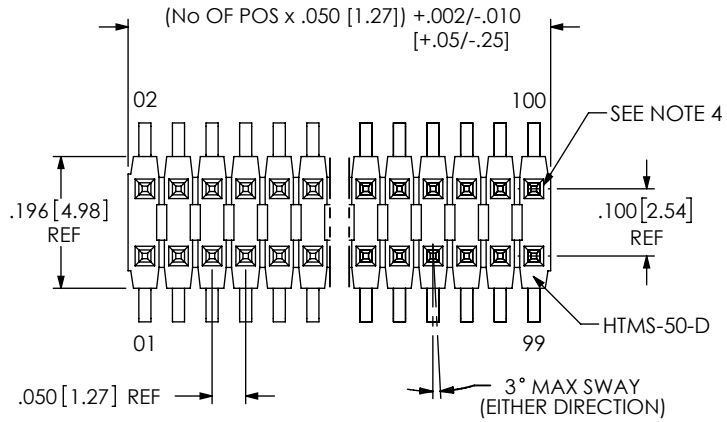

No OF POSITIONS
-02 THRU -50
(PER ROW)

LEAD STYLE
SEE TABLE 1

PLATING SPECIFICATION

- G: 10µ" GOLD IN CONTACT AREA,
3µ" GOLD ON TAIL
- T: MATTE TIN CONTACT AND TAIL
(LEAD STYLES -01, -02, -03, -51, -52 ONLY)
- S: 30µ" SELECTIVE GOLD IN CONTACT AREA,
MATTE TIN ON TAIL
- F: 3µ" FLASH SELECTIVE GOLD IN CONTACT AREA,
MATTE TIN ON TAIL
- SM: 30µ" SELECTIVE GOLD IN CONTACT AREA,
MATTE TIN ON TAIL
- TM: MATTE TIN CONTACT AND TAIL
(LEAD STYLES -01, -02, -03, -51, -52 ONLY)
- FM: 3µ" FLASH SELECTIVE GOLD IN CONTACT AREA,
MATTE TIN ON TAIL
- H: 30µ" HEAVY GOLD IN CONTACT AREA,
3µ" GOLD ON TAIL
- L: 10µ" LIGHT SELECTIVE GOLD IN CONTACT AREA,
MATTE TIN ON TAIL

BODY SPECIFICATION

- D: DOUBLE (USE HTMS-50-D)

- OPTION
- P: PICK & PLACE PAD
(USE PPP-22)
(SEE FIG 3, SHT 2)
[5 POS MIN]
 - TR: TAPE AND REEL PACKAGING
(POSITIONS -02 THROUGH -50)

OPTION

- A: ALIGNMENT PIN (5 POS MIN)
(SEE FIG 2, SHT 2)
SAMTEC DISCRETION ON WHICH
-A PIN USED.
- LC: STAKED LOCKING CLIP (USE LC-05-TM)
(SEE FIG 4, SHT 2 & NOTE 10)
- XX: POLARIZING SPECIFICATION
XX INDICATES POS TO BE OMMITED

LEAD STYLE	TERMINAL SPEC.	"B"
-01	T-1M6-13-X-2	.230 [5.84]
-02	T-1M6-04-X-2	.100 [2.54]
-03	T-1M6-04-X-2	.125 [3.18]
-51	T-1M6-13-X-2	.190 [4.83]
-52	T-1M6-13-X-2	.205 [5.21]
-53	T-1M6-05-X-2	.285 [7.24]
-54	T-1M6-15-X-2	.335 [8.51]
-55	T-1M6-16-X-2	.390 [9.91]
-56	T-1M6-16-X-2	.405 [10.29]
-57	T-1M6-16-X-2	.430 [10.92]

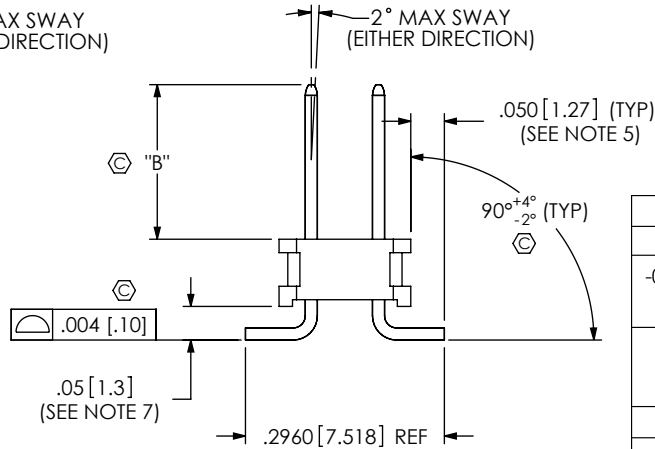
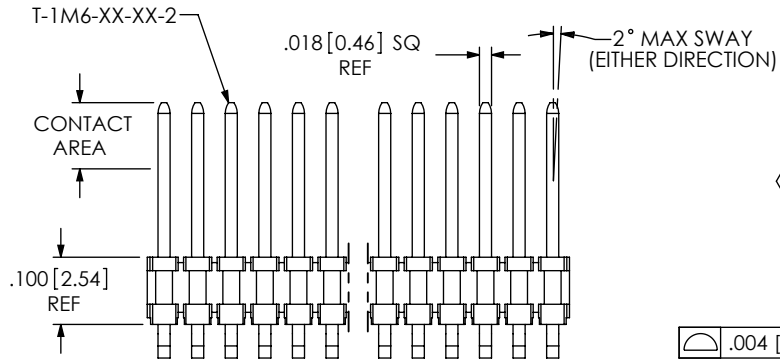

LEAD STYLE	PACKAGING TUBE	PLUG
-01, -02, -03, -51 -52	PT-1-24-02-44 (SEE NOTE 8)	TP-03
-01-P, -02-P -03-P, -51-P -52-P	PT-1-24-02-44 (SEE NOTE 9)	TP-03
-53, -54	PT-1-24-01-29 (SEE NOTE 8)	TP-03
-55, -56, -57	PT-1-24-09-29 (SEE NOTE 8)	TP-03
-53-P	PT-1-24-03-44 (SEE NOTE 9)	TP-03
-54-P, -55-P -56-P, -57-P	PT-1-24-05-44 (SEE NOTE 9)	TP-03

NOTES:

1. Ⓢ REPRESENTS A CRITICAL DIMENSION.
2. MAXIMUM CUT FLASH: .010[.25].
3. MINIMUM PUSHOUT FORCE: 2 LB.
4. MAXIMUM PIN ROTATION IN BODY: 2°.
5. SHEAR TAILS TO DIMENSION SHOWN.
6. MAXIMUM BURR ALLOWANCE: .003[.08]
7. MEASURED AT BEND RADIUS.
8. TUBE POSITIONS -05 AND GREATER; LAYER PACKAGE POSITIONS -02 THRU -04.
9. -P OPTION: TUBE POSITIONS -07 THRU -50; ALL OTHERS, TAPE & REEL ONLY.
10. DUE TO HIGH AMOUNT OF INSERTION FORCE NEEDED, THE -LC OPTION IS NOT COMPATIBLE WITH AUTO PLACEMENT. SAMTEC RECOMMENDS MANUAL PLACEMENT FOR ALL ASSEMBLIES WITH THE -LC OPTION.

FIG 1
FTR-1XX-XX-D SHOWN

UNLESS OTHERWISE SPECIFIED, DIMENSIONS ARE IN INCHES.

TOLERANCES ARE:

DECIMALS	ANGLES
.X: ±.1 [2.5]	
.XX: ±.01 [.3]	2°
.XXX: ±.005 [0.13]	
.XXXX: ±.0020 [0.051]	

PROPRIETARY NOTE

THIS DOCUMENT CONTAINS CONFIDENTIAL AND PROPRIETARY INFORMATION AND ALL DESIGN, MANUFACTURING, REPRODUCTION, USE, PATENT RIGHTS AND SALES RIGHTS ARE EXPRESSLY RESERVED BY SAMTEC, INC. THIS DOCUMENT SHALL NOT BE DISCLOSED, IN WHOLE OR PART, TO ANY UNAUTHORIZED PERSON OR ENTITY NOR REPRODUCED, TRANSFERRED OR INCORPORATED IN ANY OTHER PROJECT IN ANY MANNER WITHOUT THE EXPRESS WRITTEN CONSENT OF SAMTEC, INC.



520 PARK EAST BLVD, NEW ALBANY, IN 47150
PHONE: 812-944-6733 FAX: 812-948-5047
e-Mail info@SAMTEC.com code 55322

MATERIAL: DO NOT SCALE DRAWING SHEET SCALE: 2:1
INSULATOR: LCP, UL 94 VO, COLOR: BLACK
TERMINAL: PHOS BRONZE

DESCRIPTION:
HI-TEMP TERMINAL MICRO-STRIP (DOUBLE ROW)

DWG. NO.
FTR-1XX-XX-XX-D-XX-XX

BY: DEAN P 12/12/2000 SHEET 1 OF 3

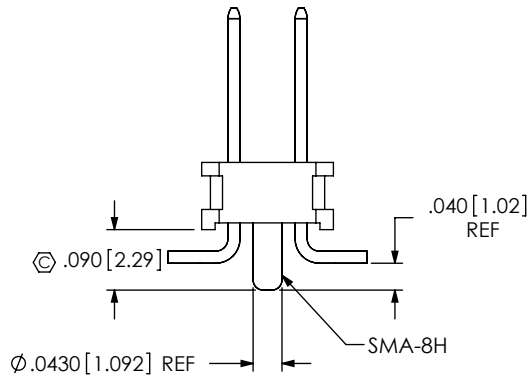
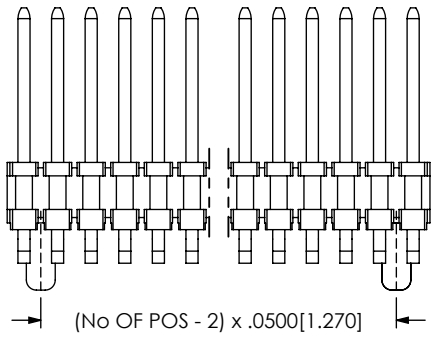

STAKED
(5 POSITIONS MINIMUM)

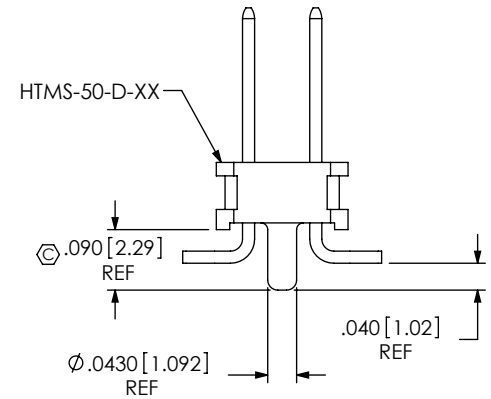
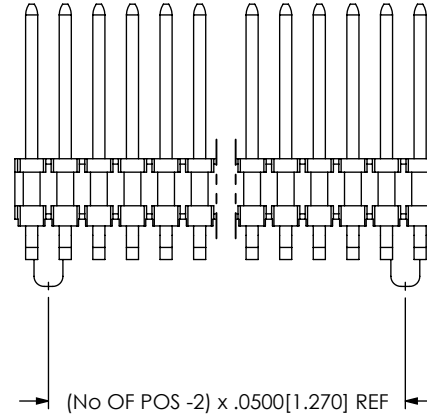

MOLDED
(5 POSITIONS MINIMUM)

FIG 2
-A OPTION: ALIGNMENT PIN
(DIFFERENT AS SHOWN, OTHERWISE SEE FIG 1)

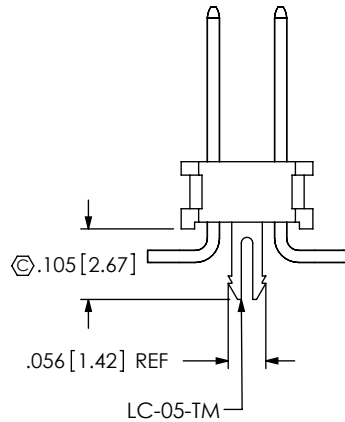
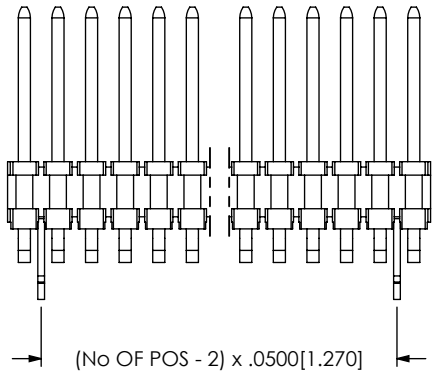
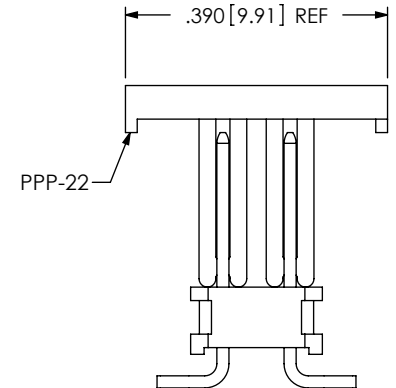
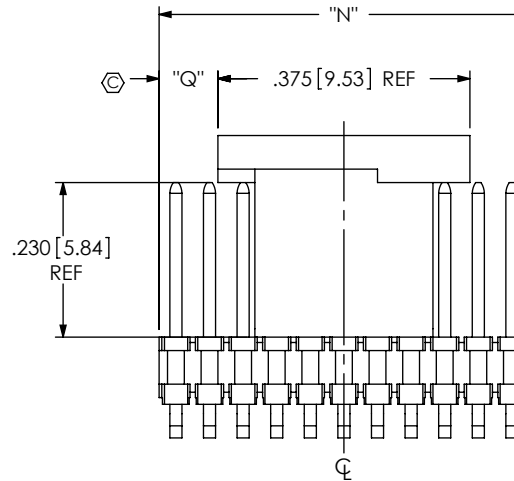

FIG 4
-LC OPTION: STAKED LOCKING CLIP
(6 POSITIONS MINIMUM)
(DIFFERENT AS SHOWN, OTHERWISE SEE FIG 1)



"N" = USE MEASURED DIM
"Q" = {"N" - .375} / 2 ± .020

FIG 3
-P PICK & PLACE
(5 POSITIONS MINIMUM, SEE NOTE 9)

PROPRIETARY NOTE
THIS DOCUMENT CONTAINS CONFIDENTIAL AND PROPRIETARY INFORMATION AND ALL DESIGN, MANUFACTURING, REPRODUCTION, USE, PATENT RIGHTS AND SALES RIGHTS ARE EXPRESSLY RESERVED BY SAMTEC, INC. THIS DOCUMENT SHALL NOT BE DISCLOSED, IN WHOLE OR PART, TO ANY UNAUTHORIZED PERSON OR ENTITY NOR REPRODUCED, TRANSFERRED OR INCORPORATED IN ANY OTHER PROJECT IN ANY MANNER WITHOUT THE EXPRESS WRITTEN CONSENT OF SAMTEC, INC.

DO NOT SCALE DRAWING

SHEET SCALE: 2:1



520 PARK EAST BLVD, NEW ALBANY, IN 47150
PHONE: 812-944-6733 FAX: 812-948-5047
e-Mail: info@SAMTEC.com code 55322

DESCRIPTION:
HI-TEMP TERMINAL MICRO-STRIP (DOUBLE ROW)

DWG. NO. FTR-1XX-XX-XX-D-XX-XX

BY: DEAN P 12/12/2000 SHEET 2 OF 3

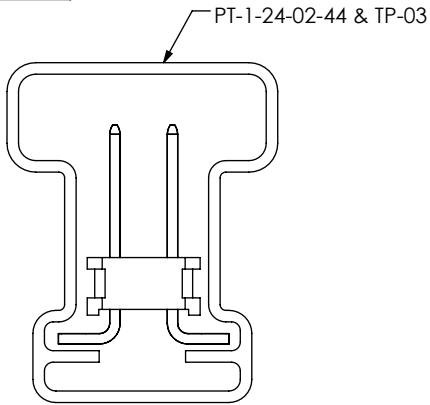

-01, -02, -03, -51 & -52 LEAD STYLES

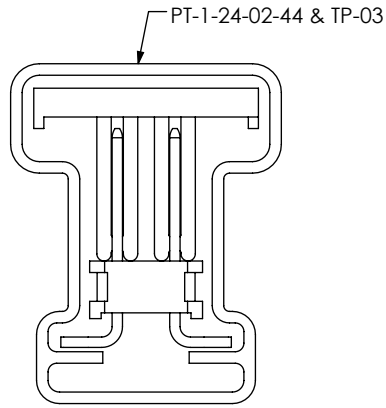

-01-P, -02-P, -03-P, -51-P & -52-P LEAD STYLES

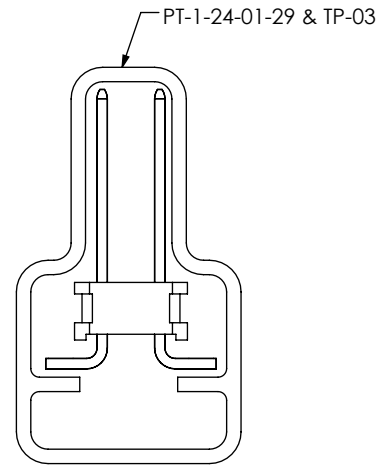

-53 & -54 LEAD STYLES

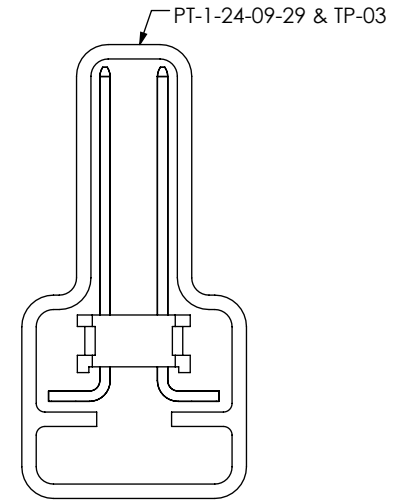

-55, -56 & -57 LEAD STYLES

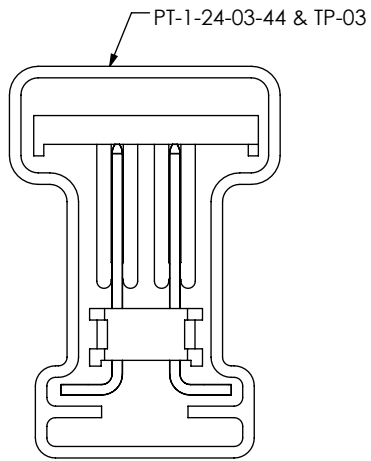

-53-P LEAD STYLE

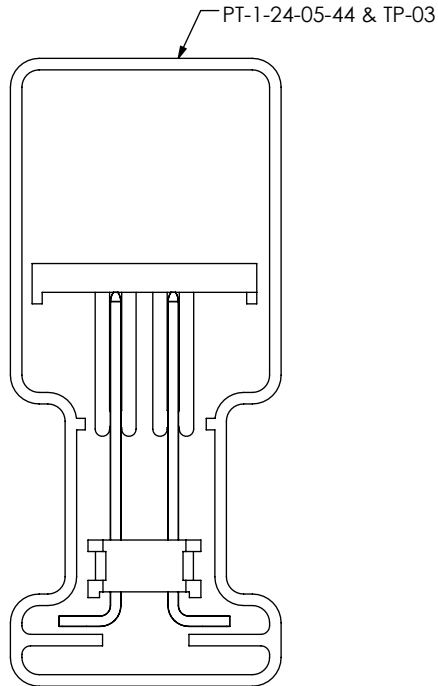

-54-P, -55-P, -56-P & -57-P LEAD STYLES

PACKAGING VIEWS

PROPRIETARY NOTE
 THIS DOCUMENT CONTAINS CONFIDENTIAL AND PROPRIETARY INFORMATION AND ALL DESIGN, MANUFACTURING, REPRODUCTION, USE, PATENT RIGHTS AND SALES RIGHTS ARE EXPRESSLY RESERVED BY SAMTEC, INC. THIS DOCUMENT SHALL NOT BE DISCLOSED, IN WHOLE OR PART, TO ANY UNAUTHORIZED PERSON OR ENTITY NOR REPRODUCED, TRANSFERRED OR INCORPORATED IN ANY OTHER PROJECT IN ANY MANNER WITHOUT THE EXPRESS WRITTEN CONSENT OF SAMTEC, INC.



520 PARK EAST BLVD, NEW ALBANY, IN 47150
 PHONE: 812-944-6733 FAX: 812-948-5047
 e-Mail info@SAMTEC.com code 55322

DO NOT SCALE DRAWING

SHEET SCALE: 3:1

DESCRIPTION:
 HI-TEMP TERMINAL MICRO-STRIP (DOUBLE ROW)

DWG. NO.
FTR-1XX-XX-XX-D-XX-XX

BY: DEAN P 12/12/2000 SHEET 3 OF 3