

DO NOT SCALE FROM THIS PRINT

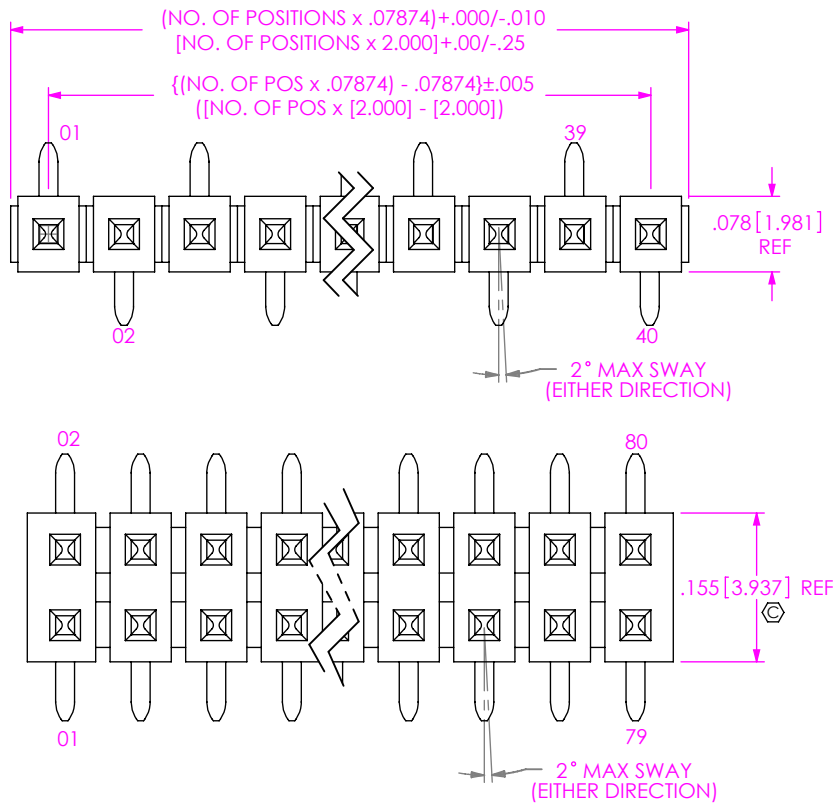

NO. OF POSITIONS PER ROW
-02 THRU -40

TERMINAL SPEC

- 01: USE T-1S13-07-X-2
- 04: USE T-1S13-04-X-2
- 05: USE T-1S13-21-X-2
- 06: USE T-1S13-08-X-2 (SEE NOTE 8)

PLATING SPECIFICATION

- G: 20µ" GOLD ON CONTACT AREA, 3µ" GOLD ON TAIL
- T: MATTE TIN ON CONTACT AND TAIL
- S: 30µ" SELECTIVE GOLD ON CONTACT, MATTE TIN ON TAIL
- L: 10µ" SELECTIVE GOLD ON CONTACT, MATTE TIN ON TAIL
- F: 3µ" SELECTIVE GOLD ON CONTACT, MATTE TIN ON TAIL
- H: 30µ" GOLD ON CONTACT, 3µ" GOLD MIN ON TAIL
- SM: 30µ" SELECTIVE GOLD ON CONTACT, MATTE TIN ON TAIL
- TM: MATTE TIN ON CONTACT AND TAIL
- LM: 10µ" SELECTIVE GOLD ON CONTACT, MATTE TIN ON TAIL
- FM: 3µ" SELECTIVE GOLD ON CONTACT, MATTE TIN ON TAIL

OPTION

- P: PICK & PLACE PAD (AVAILABLE ON POSITIONS -03 THRU -40) (SEE SHEET 2, FIG 2)
- *-M: METAL PICK & PLACE PAD (SEE SHEET 2, FIG 2) (4 POS. MIN)
- A: ALIGNMENT PIN (SEE SHEET 2, FIG 3) (5 POS. PER ROW MINIMUM) (NOT AVAILABLE ON SINGLE BODY SPECIFICATION)
- TR: TAPE & REEL (AVAILABLE ON POS -03 THRU 36, POS 37 THRU -40 AVAILABLE TO EXISTING CUSTOMERS ONLY) (SEE SHEET 3) (SEE NOTE 11)
- FR: FULL REEL QTY. TAPE & REEL (AVAILABLE ON POS -03 THRU 36, POS 37 THRU -40 AVAILABLE TO EXISTING CUSTOMERS ONLY) (SEE NOTE 12)

OPTION

POLARIZED SPECIFY POS-XX AS POS TO BE OMITTED

OPTION

-SM: SURFACE MOUNT

BODY SPECIFICATION

- S: SINGLE (TMM-50-S)
- D: DOUBLE (TMM-50-D)

* FOR EXISTING CUSTOMERS ONLY

TABLE 3

No OF POS	Diagram
-02 THRU -10	
-11 THRU -40	

TABLE 2

LEAD STYLE	"A" POST	"B" (OAL)	"C"
-01	.126 [3.20]	.302 [7.67]	N/A
-04	.075 [1.91]	.255 [6.48]	.106 [2.69]
-05	.065 [1.65]	.323 [8.20]	.106 [2.69]
-06	.168 [4.27]	.476 [12.09]	N/A

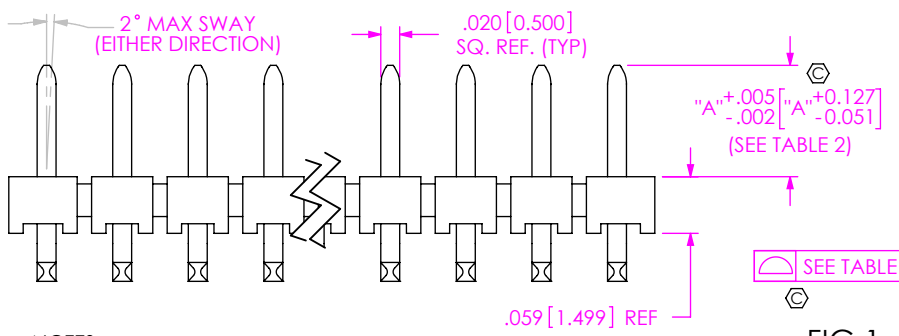
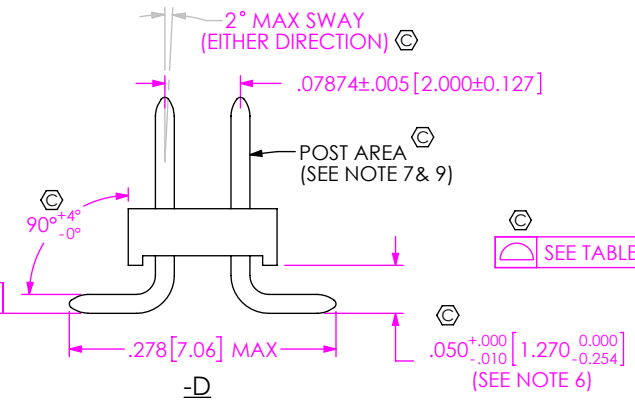
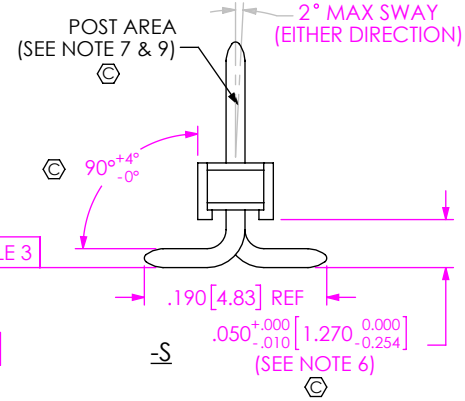

FIG 1



-D



- NOTES:
1. Ⓢ REPRESENTS A CRITICAL DIMENSION.
 2. MAX. PIN ROTATION IN BODY: 2°
 3. PUSHOUT FORCE SHALL BE 1 lb MIN.
 4. ALL DIMENSIONS IN BRACKETS [] TO BE MILLIMETERS.
 5. PACKAGE POSITIONS 03-40 IN TUBES; LAYER PACKAGE -02 POSITION.
 6. .050 [1.27] DIMS TO BE CHECKED AT BEND RADIUS, NOT AT END OF PIN.
 7. PINS TO BE INSERTED TAIL SIDE FIRST TO AVOID SCRATCHES ON CONTACT.
 8. SHEAR TAILS FOR -05 & -06 LEAD STYLE.
 9. NO BANDOLIER MARKS ARE ALLOWED IN THE POST AREA.
 10. MAX. CUT FLASH: .010 [.25].
 11. -TR OPTION ORDERS INVOLVING PARTIAL REEL QUANTITIES MAY BE PACKAGED ACCORDING TO THE SAMTEC PACKAGING EFFICIENCY STANDARDS (SPES) FOUND ON WWW.SAMTEC.COM.
 12. -FR OPTIONS WILL BE SHIPPED AT THE MAX QUANTITY PER REEL, BASED ON OPTIONS SELECTED.

UNLESS OTHERWISE SPECIFIED, DIMENSIONS ARE IN INCHES. TOLERANCES ARE:

DECIMALS	ANGLES
.XX: ±.01	2°
.XXX: ±.005	
.XXXX: ±.0020	

PROPRIETARY NOTE
THIS DOCUMENT CONTAINS CONFIDENTIAL AND PROPRIETARY INFORMATION AND ALL DESIGN, MANUFACTURING, REPRODUCTION, USE, PATENT RIGHTS AND SALES RIGHTS ARE EXPRESSLY RESERVED BY SAMTEC, INC. THIS DOCUMENT SHALL NOT BE DISCLOSED, IN WHOLE OR PART, TO ANY UNAUTHORIZED PERSON OR ENTITY NOR REPRODUCED, TRANSFERRED OR INCORPORATED IN ANY OTHER PROJECT IN ANY MANNER WITHOUT THE EXPRESS WRITTEN CONSENT OF SAMTEC, INC.

DO NOT SCALE DRAWING SHEET SCALE: 4:1

MATERIAL BODIES: LCP UL 94 VO, COLOR BLACK
TERMINALS: PHOSPHOR BRONZE

F:\DWG\MISC\MKTG\TMM-1XX-XX-XX-X-SM-XX-X-MKT.SLDDRW



520 PARK EAST BLVD, NEW ALBANY, IN 47150
PHONE: 812-944-6733 FAX: 812-948-5047
e-Mail: info@SAMTEC.com code 53322

DESCRIPTION: 2MM TERMINAL STRIP ASSEMBLY

DWG. NO. TMM-1XX-XX-XX-X-SM-XX-X

BY: REIDINGER 05-22-1991 SHEET 1 OF 3

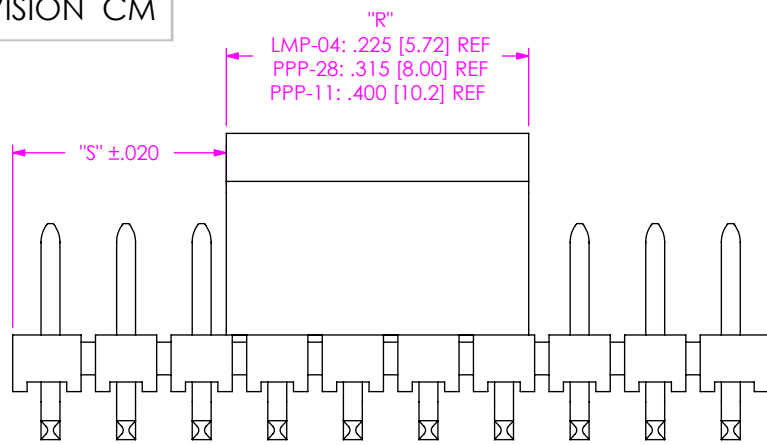

"R"= PAD SIZE ABOVE
"S" = ((No OF POS x .07874)-"R")/2

-P: PICK & PLACE PAD

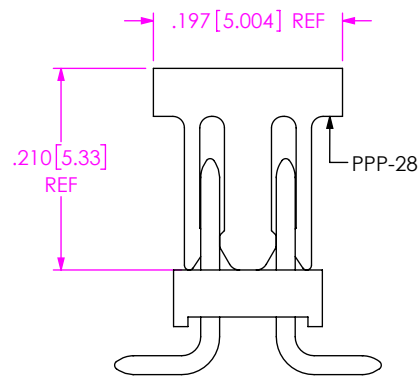

DOUBLE
FIG 2

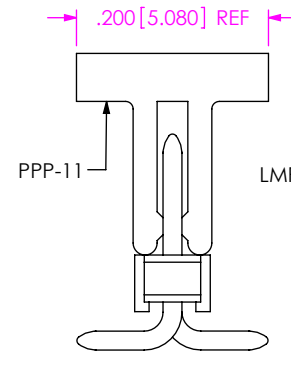

SINGLE

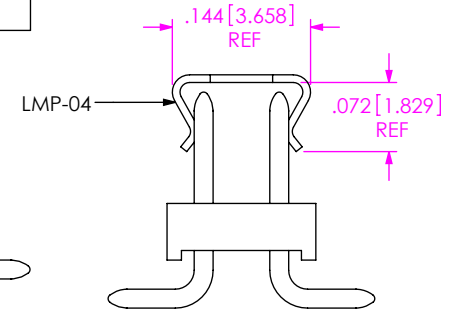

-M: PICK & PLACE PAD
DOUBLE ONLY

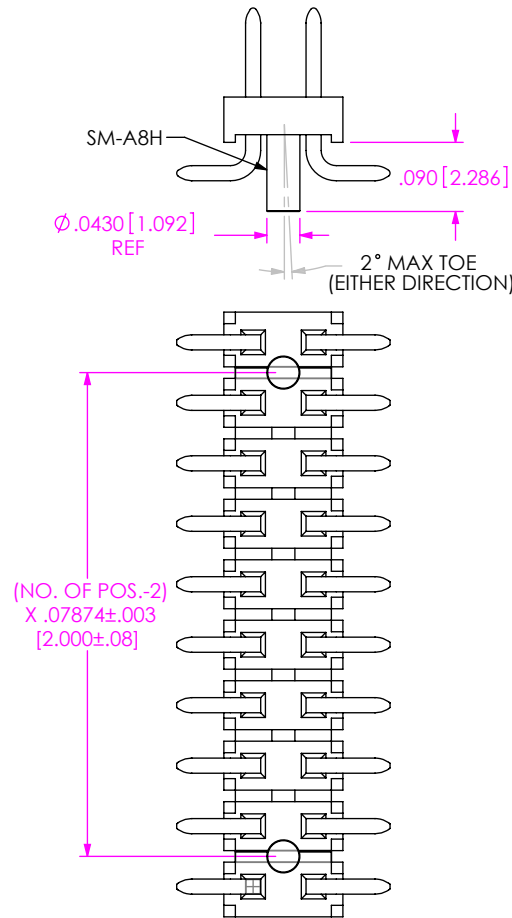
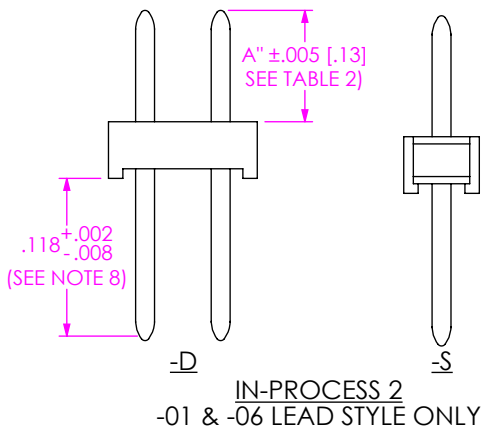
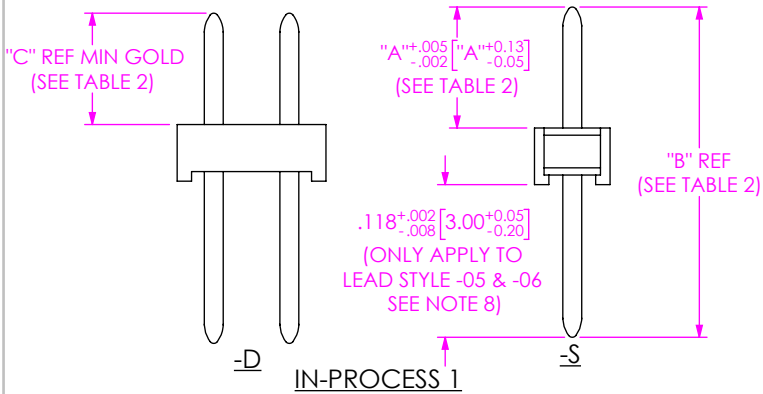

FIG 3
-A: ALIGNMENT PIN
(5 POS. PER ROW MINIMUM)

F:\DWG\MISC\MKTG\TMM-1XX-XX-XX-X-SM-XX-X-MKT.SLDDRW

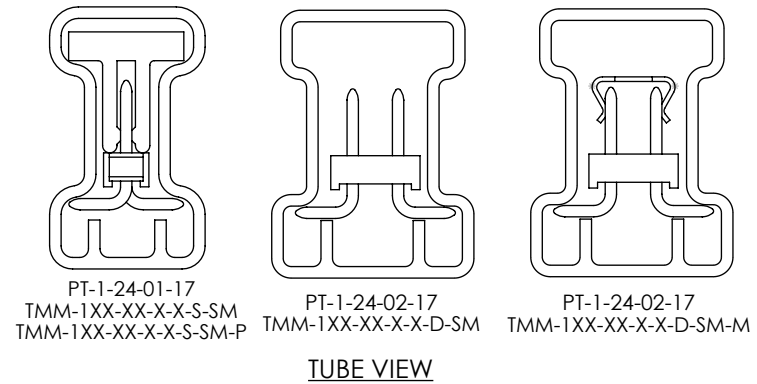

TABLE 1 (SEE NOTE 5)		
OPTION	PKG TUBE	PLUG
-S, -S-P	PT-1-24-01-17	TP-24
-D, -D-A, -D-M, -D-A-M, -D-P, D-A-P	PT-1-24-02-17	TP-03

PROPRIETARY NOTE

THIS DOCUMENT CONTAINS CONFIDENTIAL AND PROPRIETARY INFORMATION AND ALL DESIGN, MANUFACTURING, REPRODUCTION, USE, PATENT RIGHTS AND SALES RIGHTS ARE EXPRESSLY RESERVED BY SAMTEC, INC. THIS DOCUMENT SHALL NOT BE DISCLOSED, IN WHOLE OR PART, TO ANY UNAUTHORIZED PERSON OR ENTITY NOR REPRODUCED, TRANSFERRED OR INCORPORATED IN ANY OTHER PROJECT IN ANY MANNER WITHOUT THE EXPRESS WRITTEN CONSENT OF SAMTEC, INC.

DO NOT SCALE DRAWING

SHEET SCALE: 4:1



520 PARK EAST BLVD, NEW ALBANY, IN 47150
PHONE: 812-944-6733 FAX: 812-948-5047
e-Mail info@SAMTEC.com code 55322

DESCRIPTION:
2MM TERMINAL STRIP ASSEMBLY

DWG. NO.
TMM-1XX-XX-XX-X-SM-XX-X

BY: REIDINGER 05-22-1991 SHEET 2 OF 3

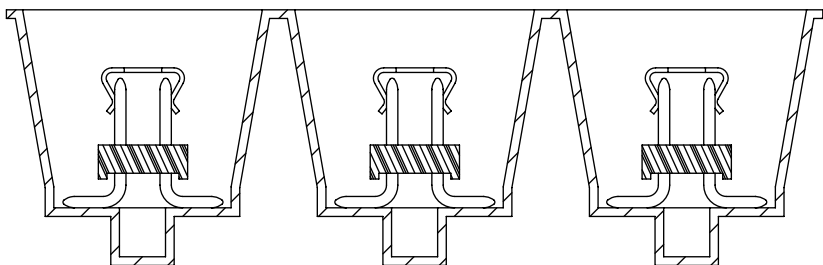
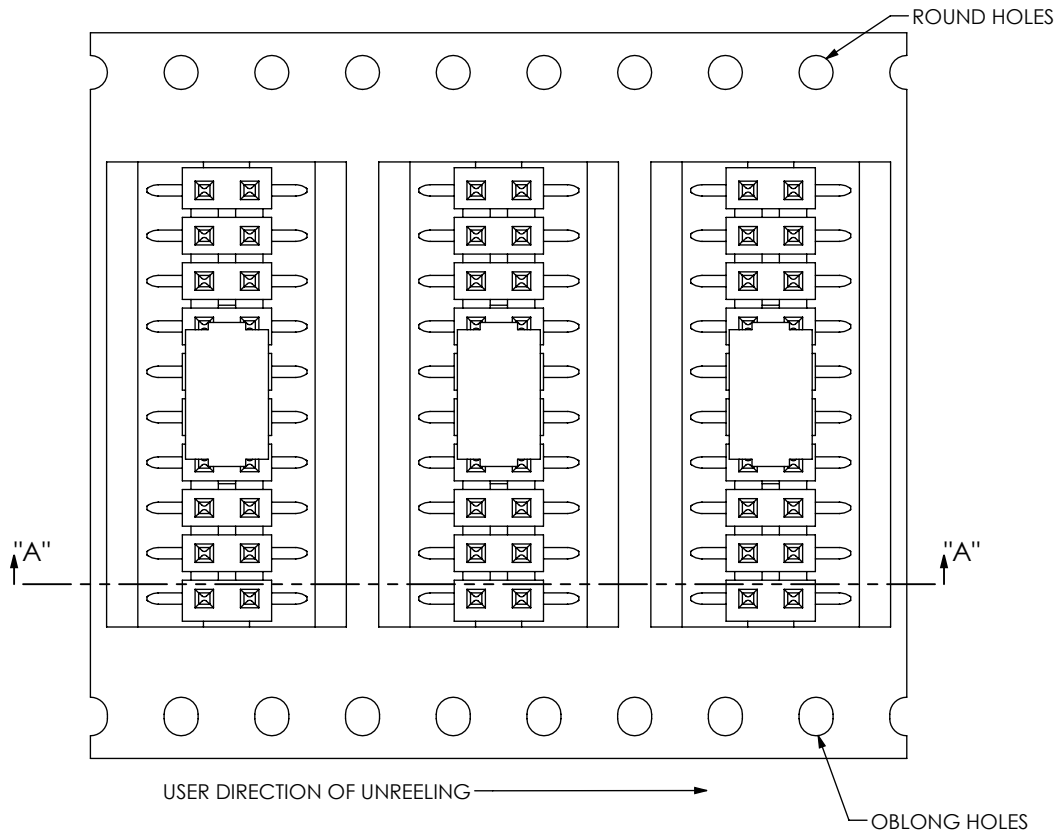

TAPE AND REEL VIEW

F:\DWG\MISC\MKTG\TMM-1XX-XX-XX-X-SM-XX-X-MKT.SLDDRW

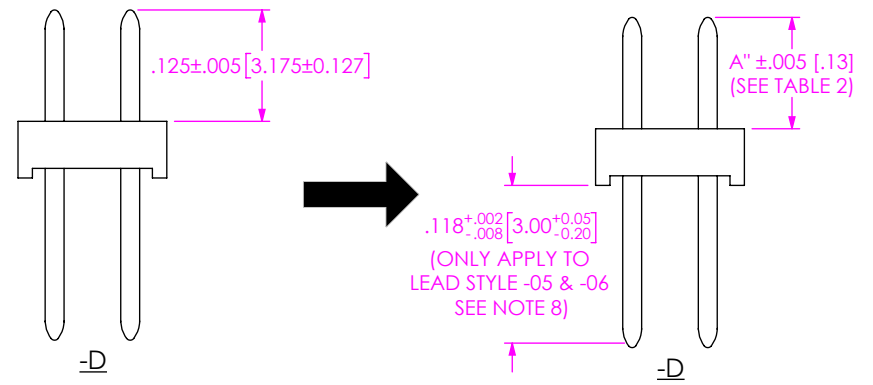

IN-PROCESS 2
(FOR -04 & -05 LEAD STYLE ONLY)

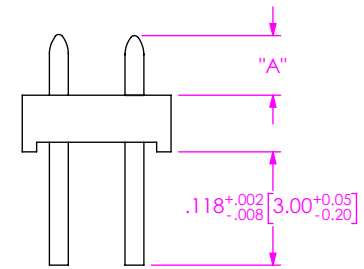

SHEAR VIEW FOR 05 & 06 LEAD STYLE

PROPRIETARY NOTE

THIS DOCUMENT CONTAINS CONFIDENTIAL AND PROPRIETARY INFORMATION AND ALL DESIGN, MANUFACTURING, REPRODUCTION, USE, PATENT RIGHTS AND SALES RIGHTS ARE EXPRESSLY RESERVED BY SAMTEC, INC. THIS DOCUMENT SHALL NOT BE DISCLOSED, IN WHOLE OR PART, TO ANY UNAUTHORIZED PERSON OR ENTITY NOR REPRODUCED, TRANSFERRED OR INCORPORATED IN ANY OTHER PROJECT IN ANY MANNER WITHOUT THE EXPRESS WRITTEN CONSENT OF SAMTEC, INC.

DO NOT SCALE DRAWING

SHEET SCALE: 1:1



520 PARK EAST BLVD, NEW ALBANY, IN 47150
PHONE: 812-944-6733 FAX: 812-948-5047
e-Mail: info@SAMTEC.com code 55322

DESCRIPTION:
2MM TERMINAL STRIP ASSEMBLY

DWG. NO.
TMM-1XX-XX-XX-X-SM-XX-X

BY: REIDINGER 05-22-1991 SHEET 3 OF 3